

CORSAIR<sup>TM</sup>  
MARINE  
INTERNATIONAL



[www.corsairmarine.com](http://www.corsairmarine.com)

# SAILING MANUAL

# Sailing manual applicable to Corsair Trimarans

*This manual has been compiled to help you to operate your craft with safety and enjoyment. It contains details of the craft; the equipment supplied or fitted; its systems, and information on its operation and maintenance. Please read it carefully and familiarize yourself with the craft before using it.*

*If this is your first craft, or you are changing to a type of craft you are not familiar with, for your own comfort or safety, please ensure that you obtain handling and operating experience before assuming command of the craft. Your dealer or national sailing federation or yacht club will be pleased to advise you of local sailing schools or competent instructors.*

**PLEASE KEEP THIS MANUAL IN SECURE PLACE, AND PASS ON TO THE NEW OWNER WHEN YOU SELL THE CRAFT**

Model: \_\_\_\_\_

Hull Number: \_\_\_\_\_

Owner1: \_\_\_\_\_

Owner2: \_\_\_\_\_

Owner3: \_\_\_\_\_

\_\_\_\_\_

\_\_\_\_\_

\_\_\_\_\_

\_\_\_\_\_

\_\_\_\_\_

\_\_\_\_\_

\_\_\_\_\_

\_\_\_\_\_

\_\_\_\_\_

Built by:

**Corsair Marine International**

7 Go O Moi Street, Phu Thuan Ward, District 7, HCMC, Vietnam

T: (+84 8) 3873 3620 | F: (+84 8) 3873 3621

E: [info@corsairmarine.com](mailto:info@corsairmarine.com)

[www.corsairmarine.com](http://www.corsairmarine.com)

# TABLE OF CONTENTS

GENERAL	4
PREPARATION	4
LOADING	4
SAFETY COMPARTMENT	5
OUTBOARD MOTOR	5
TRAILERING	5
RIGGING	6
LAUNCHING	9
MAST RAISING ON THE WATER	11
RUDDER	11
DAGGERBOARD	11
MAST SETUP	11
SAILING	12
THE BASICS	12
ROTATING MAST CONTROL	13
WINDWARD PERFORMANCE	14
REACHING	14
SCREACHER	14
SPINNAKER	15
SPINNAKER JIBING	15
SPINNAKER SAILING DOWNWIND	15
SAFE SAILING RECOMMENDATIONS	16
SAILING HINTS	17
ANCHORING	18
BEACHING	18
RETRIEVING TO TRAILER	18
DE-RIGGING	19
LIFTING OUT	20
MARINA DOCKING	20
SAFETY	20
UNSINKABILITY	21
OFFSHORE SAILING	21
CAPSIZE	21
RIGHTING	22
PERSONAL RESPONSIBILITY	24
SAFETY IN GENERAL	24
TECHNICAL NOTES	24
SPECIFICATIONS	27
CORSAIR SAIL PLANS:	28
CORSAIR ACCOMODATION PLANS	35
CORSAIR DECK LAYOUTS	37
TYPICAL TRAILER SETUP	55
MAINTENANCE & SAFETY CHECKLIST	55
CORSAIR DEALERS WORLDWIDE	58



## GENERAL

*This manual contains important information about the safe operation and maintenance of your Corsair built trimaran. Read it carefully, become familiar with the procedures described and follow the recommendations to help make your sailing enjoyable and trouble-free.*

Corsair trimarans are designed and built as high performance cruising trimarans, which when used as intended, with their enormous stability and unsinkability, are among the safest and fastest trimarans afloat.

## PREPARATION

Before going sailing, you will need to provide the proper safety equipment as required by local regulations. This will usually include life jackets for all crew members, safety harnesses for children, anchor, compass, bilge pump, fog horn, first aid kit, fire extinguishers, flashlight and batteries, life buoy, flares, a chart of the area to be sailed, food, water and adequate fuel. \*Check the weather forecast; know into what weather you might be sailing.

## LOADING

Multihulls should be treated like aircraft when it comes to loading. Corsair trimarans are light and responsive craft. Due to their narrow waterline they do not have an unlimited load carrying ability. Overloading can affect performance and handling, while excessive overloading can also affect safety margins. The ratio of the float buoyancy is relative to the total weight falling. A higher ratio is faster and safer. Always be conscious of weight and take care not to carry unnecessary items.

The load-carrying capacities of the different Corsair models are listed in the back of this manual. Some overloading is acceptable for general sailing in sheltered waters, the only adverse affect being a loss in performance. However, an overloaded boat offshore in large waves can become dangerous due to greater loads generated in the structure, and the sluggishness which can prevent the boat from rising to go over or with the waves, as it should.

When storing supplies try to keep all heavy items located as low down as possible and in the **forward end of the cabin**. Avoid storing any heavy items inside aft of the main entry hatch, as too much weight aft can cause transom drag, affecting performance. Corsair models have a very buoyant bow, which actually **lifts** at speed, and additional weight should always be kept forward rather than aft.

Should your model have float storage, avoid heavy loads in the floats. These should only be used for light bulky items such as sails, fenders etc. Heavy weight in the ends of any boat, be it the bow, stern, or floats, can adversely affect the general motion.

To maintain a light boat and that sparkling edge to performance, it is highly recommended that you go through everything on board several times a year and take off any items that do not get used. This prevents the gradual buildup of unnecessary weight.

## SAFETY COMPARTMENT

Before sailing, it is important that the safety compartment be loaded with the appropriate safety gear. This compartment is accessible from top or bottom and is usually located in a cockpit coaming or under the cockpit seat. Its purpose is to keep important safety equipment that should be available to crew in any emergency situation, including a capsize. The equipment stored here should include flares, a handheld VHF radio, EPIRB (offshore), extra line, spare tools, cutting implements etc. and all **in watertight bags** (this is not a watertight compartment). **No multihull should venture offshore without safety gear in such a compartment.**

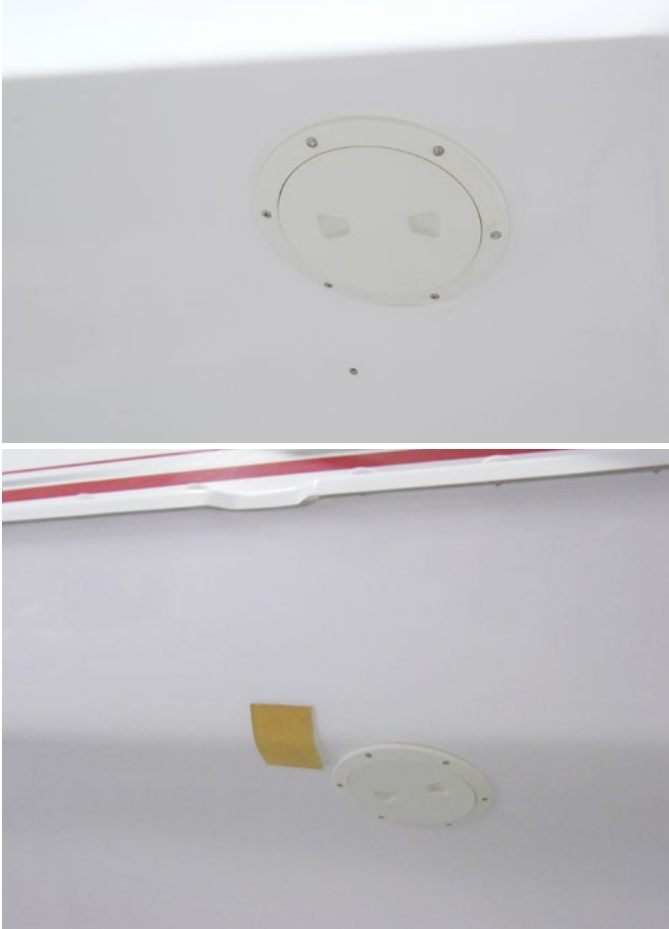

(Bottom safety compartment hatch C28 & Sprint 750 MKII.)



A Dash MKI showing the dagger style rudder mounted on transom. The rudder blade can be removed and stowed for transport.

## OUTBOARD MOTOR

The recommended motor size is given in the specifications at the back of this manual and this is more than adequate for most circumstances.

A long shaft motor is the minimum required and the **extra long 25" shaft motors are the best.** A remote control can also help make operation easy with aft cabin models. With weight being important, try to choose a light outboard.

There are a number of eco-friendly 'Sail Boat' motors now available and some of these are designed for heavy, hard to push displacement boats and their propellers are effectively 'geared down' to give high thrust at low speeds. However, Corsair trimarans have a very easily driven hull and may not need such a propeller. The result can be the same as always driving your car in low gear. You will have plenty of thrust, but speed is low, and economy can be poor. These motors do have advantages and if used, you may need to experiment with different propellers to get the best and most efficient performance. Refer to the engine manual for details of operation, maintenance and winter storage. Always be sure you have enough fuel for your planned trip. The motor can be used while the floats are extended or folded but should always be tilted up when sailing.

The dagger board **should always be down** when motoring to prevent any sideways movement. If not, the boat will have a hovercraft like motion with wide skidding turns. With the board down, handling is excellent.

## TRAILERING

The total towing weight can vary considerably depending on the model and options and can be determined exactly by using a weighbridge. Check that the vehicle is approved and equipped as recommended by its manufacturer for towing this weight and the capacity of the towing hitch is suitable.

While towing, watch for strong crosswinds. A Corsair is a relatively light boat for towing, but it still has considerable wind age. For easy, stable towing, the trailer should be balanced to have 5 to 10% of the total weight on the coupling ball. This can be measured by a bathroom scale. If you find 'fish tailing' occurs, increase this weight. If necessary, a simple change like shifting the gas tank or outboard forward can make a considerable difference to trailer behavior.

Trailer lights are fitted either on special brackets or as a separate light bar on the boat's transom. They are thus independent from the trailer, and the wiring never gets near the water, considerably improving reliability. If separate, be sure to fit the correct lights on the appropriate sides. The wire should be run along the top of the boat, looped around the foredeck cleat and then connected to the towing vehicle. Independent wiring

avoid the frequent breakdowns that occur with wiring through the trailer being towed on its own, the lights can be mounted directly to the trailer.

Before trailering, check that tires are inflated correctly, the beam locking pins are in place, the rudder is fully up and tied to one side, the poptop or hatch is secured, and the boat is tied down to the trailer. There should be one tie-down per side, these being looped around the winches or brackets on the cockpit coamings, and tied to the tie-down loops on the trailer. The bow eye should also be tied down to the winch post, in addition to the winch line. Check that all the trailer supports always bear equally against the hulls.

When trailering, **be sure** to pivot up or remove the trailer jockey wheel, and that the hitch is locked on to the ball.

Should the mast extend back past the trailer lights by more than the legal amount, the appropriate warning flag should be tied on the back. The mast can be positioned far enough forward to eliminate any excessive over, however this may not be possible if the towing vehicle is a van.

When trailering, always allow extra distance for stopping. Particularly watch for **low bridges, overhanging trees or awnings** etc. if necessary, the boat can be partially unfolded on the trailer in order to pass under a low bridge.

#### CAUTION

*Measure and know the overall height on the trailer. Care should be taken to avoid all low, overhead obstacles.*

## RIGGING

This procedure has been developed from over hundreds of launchings around the world and has proven to be safe and easy. Don't be disheartened if it takes you longer the first few times. This is not a race. After a few launchings this process will become easier as you are more familiar with your boat and your confidence builds.

Two people can have a 750, C28 rigged and launched in around 30 minutes. The Cruze 970 may take a little longer as everything is larger and heavier.

#### CAUTION

*Always park into the wind or uphill to help the mast stay in line while being winched up. Trailer should remain hooked to towing vehicle.*

#### DANGER

*Before starting to rig, check to see that there are no power lines for the mast not to touch while being raised, or while being moved to the ramp.*

Recommended setup procedure is as follows:

1. Remove the trailer tie-downs and the trailer lights. The tie-downs can be tied together and used as the bow line for launching which saves stowing them, and then finding a bow line.
2. Undo the trailer winch hook, and pull some slack so the hook will pass over the bow roller. Leave it lying on the foredeck.
3. Place the mast raising pole on the foredeck for use. Climb onto the bow using the nonskid areas on the float bows as stepping points.
4. Move aft alongside the mast undoing the mast ties (at each end) and the rigging ties as you go.
5. Lift the forward end of the mast and walk aft, rolling the mast on the aft mast roller while checking that the rigging wires do not catch. Stop once the mast foot is over the pivot brackets.



*C28 & C31 pivot brackets*

Now it is the time to fit any masthead indicator to the top of the mast. Lift the mast up until the indicator can be fitted to the masthead from the ground behind the boat. If rigging single-handedly, the mast can usually be balanced in this position to enable fitting.

With C28 & Cruze 970 rotating masts, the mast yoke now needs to be fitted to the mast foot using the through pin (yoke can also be fitted prior to rolling mast back or be left on the foot prior to de-rigging). Another alternative is to attach the yoke to the deck first, then fit the mast to it.

6. The mast foot is connected to the mast step as follows:



*Dash/Sprint 750 MKII yoke*



*C28, C31 & Cruze 970 yoke*

7. Fit the mast raising wires these are led from the eye around 8' up the front of the mast (side of the mast with non-rotating masts) to the side anchors on the cabin roof (aligned with the mast pivot point). These raising wire anchors can be 'clip on' or 'lift up loops' or extra chain plates, depending on model.



*Mast raising eye on mast*

Note that the length of these raising wires is adjustable and they should be slightly loose and monitored on the first mast raising. This is to ensure they cannot become over tight during the initial raising procedure. They should never be more than moderately tight, and once adjusted and set, should need no further monitoring or adjustment.



*Raising wire eye on cabin top*

An alternative to raising wires is to use the spinnaker and screacher halyards. These can also provide an extra backup in difficult conditions but they do take longer to setup. If used, they must be cleated at the bottom to the mast.

8. Position the mast raising pole on the mast in the yoke socket. Attach the wire from the top of the pole to the eye on the front of the mast, with the pole being approximately perpendicular to the mast.

If considered necessary, (strong cross winds or single-handed) additional light side lines can be fitted from the end to the raising wire anchors to stabilize pole sideways.

Where the yoke is used (C28 and Cruze 970 rotating masts) the length of the wire from the pole to the mast can also be adjusted, and a little experimenting will give an almost perfect moderate tension on the raising wires throughout the complete raising procedure.

9. Take the trailer winch line hook and pull it back over the pole and connect it to the jib halyard snap shackle (after it has been unhooked from the mast). Winch line should extend at least 2' aft of the mast pole fork.



*Halyard tied down as safety back up*

Check to see that the jib halyard is **securely tied off** at the cleat on the side of the mast.

#### **CAUTION**

*With rotating masts the shrouds must always be connected to the floats. Otherwise there is a danger that the mast could topple forward with over-winchng.*

10. The mast is now winched up, **checking again for power lines.**

Check to see that all rigging wires are clear and have not snagged anywhere, particularly aft chain plates on the Cruze 970. Raising wires should initially be slightly loose and tighten slightly on the way up.

## WARNING

*During mast raising it is very important to be alert to all items of rigging lifting or supporting the mast. If any resistance to raising is felt at point, stop and check that nothing has fouled. Do not proceed until any obstruction is clear.*

If the mast raising pole tends to twist sideways, this can be controlled by light lines to the raising wire anchors as mentioned earlier.



*Mast on way up and being held from going sideways by raising wires*

Check that the socket in the rotating mast foot aligns correctly with the pivot ball on the deck as the mast nears the fully up position.

## CAUTION

*Winch operator should be careful to ensure that the trailer winch line lies evenly across drum while mast is beginning to be raised. With an offset bow roller, there can be a tendency for incoming line to pile up on one side of the drum to where it can suddenly slip off.*

Monitor the float shrouds with rotating masts on initial rigging to ensure they do not become too tight or catch on anything during raising. C28 (rotating mast) have a high field lever system on the float decks that allow the shroud enough slack for the mast to be fully raised when the float is folded, while preventing any danger of the mast topping forward. The 750's special folding geometry allows this on its own.

The Cruze 970 mast is large and heavy, with high loads, and extra caution should be taken to ensure it is not able to swing too far sideways. Never park in a cross wind or sideways on a slope unless extra help is available to steady the mast.

11. Once the mast is fully up, connect forestay. For initial rigging mast rake should be set to around 3° to 4°, which is 1° to 2° more than the rake of the aft edge of the forward beams when viewed from the side. Once initial adjustment has been done, the forestay turnbuckle does not need to be undone during normal rigging or de-rigging, only the clevis pin is removed or inserted.



*Always leave mast raising wires attached until after the boat is unfolded.*

*750 'fold down' anchoring loops shown here.*

12. Once forestay is connected, slacken off the trailer winch, disconnect the jib halyard, and return it to the mast. Remove raising pole, mast yoke, rewind the winch and reconnect hook to the bow eye.  
  
Leave mast raising wires attached to the mast as these are still required for support until after the float are unfolded and shroud properly connected to floats.
13. The topping lift is now disconnected from the mast lower end and connected to the end of the boom to help take the weight. Remove the sail bag from the mainsail/boom and connect the boom to the mast.
14. Tighten all the battens in the mainsail if required. Connect the mainsheet to the boom. Feed the mainsail head into the track on the mast and connect the main halyard.



- Run all the halyard lines from the mast through the turning blocks back to the correct rope clutches on the aft end of the cabin roof.

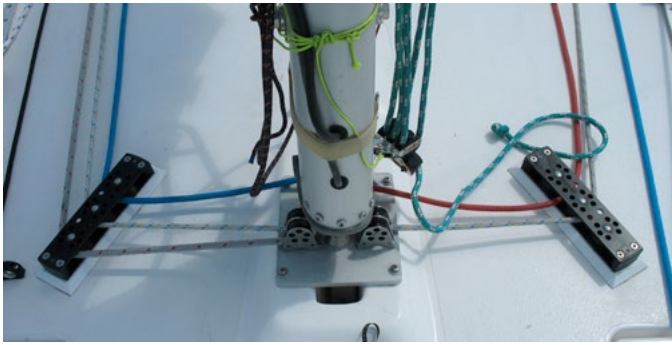

*Lead halyards like this*

- Connect the mast electric plug if required.
- The headsail can be fitted now if wished or after launching. The sheets are laid out and connected to the clew (sheets can be kept in the anchor well for quick access). The headsail can be kept under control by a shock cord which can be left on the foredeck for this purpose, just keep it hooked to the toe rail or pulpit.
- Untie the rudder and check that the dagger board up-line is cleated. The outboard motor should also be in the up position.
- The aft mast support is now removed and stored. You are now ready to launch.

## LAUNCHING

### WARNING

*Before taking the boat to the ramp first check to see there are no power lines for the mast to touch.*

Back the trailer down the ramp until the trailer is submerged up until just past the inward bend of the side frame members (about 6 to 8' back the winch post).



*Submerge trailer to inward bend*

Disconnect the winch hook and push the boat off while holding on to the bow line or you can get on board (but start the motor first before pushing off). Be careful of crosswinds or wind from the stern. The boat, with its shallow draft, will move quickly sideways in such conditions and you should not launch until there is sufficient maneuvering room alongside.

This ability to go sideways is one drawback of shallow draft and you should always make allowances when launching/retrieving or under power. First priority at every launch should be to lower the dagger board! This helps to prevent any sideways movement, and gives excellent maneuverability under power.

The Cruze 970 is a large boat to handle at ramps but because of its lightness it is easy to move around. The trick is not to fight it but to plan ahead what you are going to do and to gently guide it in the correct direction.

An offshore wind at the ramp is ideal, as the boat will just lie quietly downwind at the end of the bow line. It is then a simple matter of boarding over the float bows and backing off or just walking her over to a boarding dock, if available.

An onshore wind is the most difficult, as the boat will swing sideways once launched and come towards the ramp. In this situation the boat should be held off the ramp from a central position on the side. You will find a balance point where it will lie evenly until you are ready to board.

If a dock is alongside it is a good idea to run a stern line to the dock, so that the stern can be pulled to the dock after launching, thus preventing it from swinging around.

A good way of launching in all conditions if extra help is available is for someone on board to start the motor before launching and simply back the boat away from the ramp remembering, of course, to drop the dagger board once clear of the trailer.

All models are always launched folded, and unfolding can be done either at the dock, or while motoring away, even in choppy conditions. Folded stability is very good but it is limited, particularly on bigger boats like the C28 and Cruze 970. Always take care in strong crosswinds and avoid fast tight turns as it is possible to roll the boat over! If necessary, immediately unfold at least one side to avoid any risk. The Cruze 970 also has a secondary wider folded beam of 9' 6" which improves folded stability, and if you intend motoring very far while folded you should use this position.

## WARNING

*Always take care in strong winds while fully folded and with mast up. A combination of a fast tight turn and mast windage and weight could cause a roll over in such conditions. If in doubt unfold one or both sides to eliminate this danger.*



*Unfolding can be done at the dock or while motoring away.*

*But beware, while folding stability is very good, it is limited.*

To unfold, first check that there are no ropes across the beam recesses and the tiller is clear. Remove the beam looking pins, place your foot on the top of the upper folding strut and grasp the top of the beam and pull downwards, while pushing with your foot.

## WARNING

*Always check that no one has their foot/hand/fingers in or near the recesses when folding as the beams can come down quickly!*

The float will unfold but be careful it doesn't pick up too much speed towards the end. Hold the beam down and tighten the bolts using a speed wrench. These bolts should be tightened firmly but not over tightened.

## WARNING

*The Beam Bolts must always be in place and tightened before sailing*

If anything seems hard or difficult when folding stop and see if anything is misaligned or snagged. It is usually a wing net catching. Should you have difficulty in holding the beams down to tighten the bolts then the usual cause is wing nets that have been lashed too tightly, these should be slackened slightly.

It is not necessary to hold both forward and aft beams when folding. One person operating either beam is all that is required. The wing nets will extend and tighten themselves. There is a knack in unfolding using both your foot to push on the upper folding strut and your hands to pull the top of the beam in and down. After a few tries you will find it easy to do.



*Secure the lever by putting the locking pin through the three holes and place a locking ring.*

*You should need a bit of pressure to close the lever so there's enough tension on the shroud.*

*Used on C28 and C31*

The shrouds are now secured correctly to the floats with the link plate (if fitted) being pinned to the chain plate. The 750 MKII does not require this as its shrouds can be left permanently attached to chain plate.

Rotating mast shrouds only need to be moderately tight and even slightly loose as a tight rig can restrict rotation.

Once adjusted at initial launching all turnbuckles can remain fixed and should not require adjusting during launching or retrieving, just the spring clip and clevis pin are inserted or removed in the turnbuckle toggle or link plate.

Once the mast is properly supported by the shrouds, the mast raising wires can be removed.

The spinnaker pole bowsprit can now be fitted or extended depending on the model.



*Beam bolts must always be tightened firmly before sailing*

## MAST RAISING ON THE WATER

It may be necessary to sometimes launch with the mast down and raise the mast later. To do this you will need an additional strong block to attach to the bow roller/stern fitting. A spinnaker sheet block is ideal. The mast raising pole/yoke must also be carried on board.

Once in clear water, follow the same mast setup and raising procedures as listed under rigging but instead of the trailer winch line, use a line from a sheet winch to the bow block and then back to the jib halyard. The mast can then be winched up. The procedure is reversed for lowering.

## RUDDER



*Cruze 970 transom hung rudder being lifted up*

The rudder has 2 control lines, one to pull up and one to pull down. These are color coded with red (for danger) to pull up and blue (for deep water) to pull down. The rudder will kick back should it hit bottom hard enough, the pull down line pulling through the cleat.

At high speeds, the cleat alone may not be enough to hold the rudder down. In this case, an alloy lock/shear pin can be fitted through the case and blade as a positive lock down.

The rudder may also have an extra horn cleat on the tiller, and this should only be used if the hold down cleat is worn and the lock/shear pin is not available. Never use the horn cleat where there is a danger of grounding.

## DAGGERBOARD

Like the rudder, the dagger board has 2 control lines, one to pull up (red) and one to pull down (blue). The dagger board will not kick back, it being designed to break off should it ever hit bottom hard enough. This protects the dagger board case from damage as most cases are a much more expensive repair. Obviously, one should still be careful around shallow waters, keeping alert and the boat speed down. The dagger board is very strong and will only break off with an exceptionally hard grounding. Normally you can expect the boat to come to a shuddering stop, with no damage, should you hit bottom at speeds less than 6 knots or so. It's then just a matter of retracting the dagger board and continuing on your way.

### CAUTION

*Event at low speeds, grounding can cause the crew to be thrown forward and care should be taken to prevent this, or to be prepared for it. Slow down in shallow water.*

The dagger board case itself is exceptionally strong and is not likely to be damaged in grounding, though this cannot be guaranteed. Even with a lost dagger board, your Corsair trimaran will still be sailable and will still go to windward. In this case you should allow her to heel as far as possible, submerging the lee float to pick up lateral area.

When maneuvering in confined waters always have the board down. This promotes quick turns, preventing any sideways motion. In general, the board should always be down except perhaps when running downwind in light conditions. However, no speed advantage has ever been proven for this so it is probably easier to just leave it down.

The board should always be half to fully down when running or reaching in heavy winds or seas. It greatly enhances directional control, keeping the tiller very light.

Should you at any time find the helm heavy, then the cause is either, the dagger board is up or the rudder has kicked back slightly (always watch for this). Another possible cause can be the mainsail sheeted in too tight (a common fault). Even in the strongest winds or the fastest 20 knot spinnaker run, the helm should always be light enough for easy one-handed control. If not, you should check for reasons why.

## MAST SETUP

Rig tension and mast setup are very important for good sailing performance and while rotating masts do not require much rig tension (to allow full mast rotation), most owners do not tension fixed mast rigs enough. To avoid this, a simple rig tension gauge (loose type recommended) available at marine stores can be purchased and this includes hints on tensioning your rig. Rigging wire will stretch a little initially and all settings should be checked after a few sails.



*C28 speeding upwind with tight mainsheet*

All masts should be set up with some prebend (center of mast pushed forward). This will range from as little as 3" to 4" with rotating masts to 3" to 5" with fixed masts. Mainsail should then be cut to suit this.

There is no correct amount of prebend other than each mast should have some, and it can be used to control the mainsail shape to some. This means that if the mainsail is cut for say 3" prebend, less will make the main fuller for light airs. More will tend to flatten the main for windy conditions.

Prebend in rotating masts is harder to adjust in this regard because of the mast profile but the ability to rotate the mast can give an even greater control over mainsail fullness.

For good windward performance the forestay must be tight and thus cannot be emphasized too much. Fixed masts can control this by pulling on the shroud tensioners and more mainsheet tension but the superior mainsail shape due to the rotating mast more than makes up for this.

An important rule, vital to the well being of all masts, particularly fixed masts, is to be sure that your leeward cap shroud never becomes too loose. Some looseness is not unusual but if it is very loose and visibly flopping around, you could risk losing your mast. Loose rigging will also greatly affect the performance of your Corsair.

## SAILING

This manual is not intended to be a sailing instruction manual and it is presumed that all owners will have a basic sailing knowledge and skill. There are however, many aspects of sailing a Corsair trimaran efficiently and the following covers some of these:

## THE BASICS

The mainsail is usually hoisted first. Turn directly into the wind and commence pulling on the halyard. You may find winching necessary to get the main fully up and if fitted, use the jib halyard winch. If the boom roller furling system is fitted, the main will automatically unroll from the boom.



*Roller furled mainsail C31*

Winch the halyard tight until all the wrinkles just disappear from the mainsail luff, no tighter, and lock the halyard with the rope clutch. The topping lift can now be eased.

All models sail and tack easily under mainsail alone. If you have lot of tacking to clear a channel then it may be much easier with just the main. You don't have to worry about tacking the jib and this won't allow you to go too fast particularly in crowded waters and if there is minimal visibility.

The correct technique for sailing mainsail only is to sheet it free to avoid choking the boat. The traveler can be locked on the centerline and the mainsheet slackened off so the boom is about 12" out from center. Your boat speed should be 5 - 6 knots in 10 to 15 knots of wind, even better with a rotating mast. If you find boat speed is less then the problem is an over-sheeted main or trying to point too high.

There is a technique involved in sailing main only, and once learned how, it is a very relaxed form of sailing. The secret is to keep the main eased out more, particularly after a tack. Don't try to point high until boat speed has built up.

The jib halyard can now be connected and the jib hoisted. Tighten until the wrinkles just disappear from the jib luff, using the halyard winch if needed. There's no need to go any tighter. As the wind increases you will find the halyard will need tightening, again, just enough to just get the wrinkles out. Sheet the jib and you are sailing!

If available, two additional controls may be added to the mainsail at this stage, these being the boom vang (fixed masts only) which just snaps on, and the Cunningham eye tackle. A 4:1 fiddle block with cleat is snap shackled to the mast step and the line from the top fiddle block is passed through the Cunningham eye on the sail and hooked to the horn cleat on the side of the mast. This gives an 8:1 purchase, and should be adjusted to just remove the wrinkles from the mainsail luff. Neither of these controls are essential for everyday sailing, their main purpose being to give more efficient control over the mainsail. Both must be removed when roller furling.

Corsair trimarans are sailed like any other yacht, the most notable differences being the response, lightness of the helm and the low angle of heel. This ranges from an average of 5° to 10° to a maximum of about 15°.

Pointing ability is excellent but care must be taken not to over sheet or try to point too high. Just a few less pointing, with sheets slackened slightly, can see boat speed jump from 6 or 7 knots to 9 or 10 knots.

When reaching, the headsail shape can be improved by using a barber hauler. This is a line hooked to the headsail clew, and led to a block attached to an eye on the float deck and then back to a camcleat on the cockpit coaming. Two barber haulers give a wide

range of sheet adjustment. One can also be used on the boom to hold it down while running or reaching. This is much more efficient than the traditional boom vang and a good safety feature to prevent an unexpected jibe.

Several different reefing systems can be fitted, and all the control methods are well documented. The roller reefing boom as used on the 750/C28 and optional for the Cruze 970 is a very effective reefing system, being fast, easy to operate and infinitely adjustable. Its other main advantage is the ability to easily roll up the mainsail for storage.

To reef, first disconnect the boom vang (if fitted) and Cunningham eye tackle. The topping lift should also now be used to lift the back of the boom a couple of inches above horizontal. This stops the main from creeping forward to bind against the mast when furling. This may not be required, depending on the cut of the mainsail.

Now take the main halyard around the winch and release the rope clutch. Go forward with the halyard held in hand, unlock the furling handle and begin turning. As the main is rolled down, let the halyard slowly run out to suit. When the main is rolled up sufficiently, lock the furling handle, let off the topping lift, and return to the cockpit and retention the halyard. Reefing is complete.



*Roller furler handle*

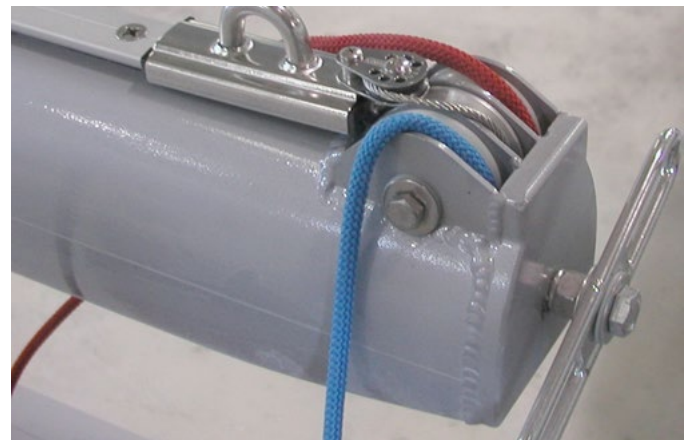

*Boom with reefing system on the Cruze 970*

You should always try to locate the head of the reefed mainsail close to or just above a staying point rather than in the middle of an unsupported mast panel. This avoids unwanted bending loads and reduces inverting the mast.

As mentioned previously, if you find a problem with the mainsail rolling up close to and jamming against the mast, this is usually caused by not lifting the end of the boom sufficiently with the topping lift.

You may also find it easier to regulate the speed at which the halyard runs out, as you wind the boom, by using the ball of your foot on the line just before it enters the mast.

A jiffy reefing system may also be fitted, in addition to the roller furling boom and this can give slightly better sail control for better sailing efficiency.

To use, simply roller reef as described above but only roll the main up until the selected jiffy reefing points are reached (two sets usually included as standard). Lock the furling handle as before and then reattach the Cunningham eye tackle to the reefing tack eye.

Now unthread the outhaul line and rethread it through the new reefing clew eye. All the controls of a jiffy reefing system are now in place except you don't have to tie off the sail it being already neatly rolled around the boom! It is advisable to take a line from the Cunningham eye forward and around the mast. This avoids the possibility of the bolt rope pulling out of the mast groove.

## ROTATING MAST CONTROL

The correct rotation of a rotating mast will give a much more efficient and powerful mainsail. It is thus important that the rig not be set up too tight as this can prevent full rotation.

There are many opinions on what the correct amount of rotation should be but a general guideline is to keep the mast rotated enough to give a smooth, even, transition from the mast to the mainsail on the leeward side.

Achieving the right amount of rotation will improve your

speed and mainsail shape by pulling the apparent breeze through the slot efficiently. The amount of rotation will vary between 35° to 90° degrees.

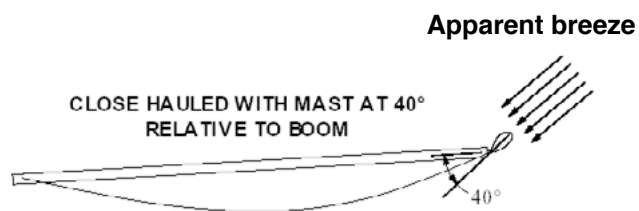

#### *Mast rotation*

Avoid allowing the mast to rotate or swing back and forth, which can happen in light winds combined with waves or when sailing off the wind with less sail pressure. This is usually prevented by having the mainsheet angled forward from the boom, which forces the boom forward to keep the mast rotated when pulled tight.

The amount of mast rotation is controlled by a line to the rotation arm on the mast from either the boom or the deck. This acts as more of a preventer than a positive control. The mast will naturally rotate in its position generally in line with the apparent breeze. The control line will prevent the mast from over rotating. A line from the boom has the advantage of being self-tacking by maintaining the mast at a constant rotation angle relative to the boom on all points of sail. However, the control line will have to be detached from a roller furling boom and transferred to an eye on the deck when furling the main.

A control line from the deck is also self-tacking, but it does not automatically adjust for different angles of sail. It will thus need to be let out when bearing off. Some racers like to fit two lines to the deck, one from each side for absolute control, but this can also be just another complication and is not necessary for general sailing.

## WINDWARD PERFORMANCE

All corsair models will point very high if set up and sailed correctly but this can also be very dependent on the crew's skill. It is possible to point just as high as a mono hull but this may not be the fastest way to windward. A good multihull is capable of much higher speeds to windward than a mono, which also brings the apparent wind forward, to where pointing is much greater.

One thing to avoid is over sheeting the headsail, while pulling this very tightly will guarantee a good pointing angle; the boat speed may be slow. The correct way is to let the sheet out 1"-2" from being tight on so that the curve of the headsail leach matches the curve of the mainsail. It should then not backwind the main and your pointing angle and boat speed should both be excellent.

Once you have achieved good boat speed, then experiment by tightening sheets very slightly, pointing

slightly higher, while trying to maintain the same boat speed.

The mainsail traveler should be around 6" to windward in lighter conditions, then around the centerline in moderate winds and as the wind increases, moved outboard slightly and more mainsheet tension applied. In very strong winds the mainsheet should be pulled on as tightly as possible. Stand above it and pull it on as hard as you can - most sailors don't have this tight enough in strong winds. A tight mainsheet helps keep the forestay straight for good pointing ability.

If the jib is back winding the main, open the slot by moving the traveler a little more to center. Keeping an open slot between jib and main is crucial to good windward performance as any back winding of the main will choke the boat. Equally as important, the jib must be relatively flat with no hook in the leach and not over sheeted. Leach battens are highly recommended to keep the leach flat.

If set up and sailed correctly, a Corsair trimaran will match the windward ability of the best mono hull racers that are 20% to 30% larger. Pointing high and going fast is one of the hardest things to achieve in any boat but with a little care and tuning a Corsair is one of the best.

Achieving good windward performance can be very satisfying but it does depend on a lot of factors being right!

## REACHING

When reaching, it is vital that the mainsail be let out far enough. A common mistake is to sheet it in too tightly resulting in loss of boat speed, a heavy helm and an excessive heel angle.

**Always remember you will generally go faster by easing the sheets out. Pulling on them tighter is more likely to slow you down.**

Your mainsail should have leach tell tails fitted as standard. Watch these, and should they disappear behind the mainsail to leeward then you are sheeted in too tightly. They should always be flowing aft.

In light winds the mainsheet system can tend to bind and be hard to let out. To overcome this there is sometimes a lever on the side of the camcleat block that disconnects the ratchet. The mainsheet system will then run out easily.

The headsail should also be barber hauled out to the floats when reaching. This is used to get the perfect shape in the headsail (so that it doesn't backwind the main) and will boost reaching performance significantly.

## SCREACHER

This is an optional roller furling wire or kevlar luff combination genoa/screacher, flown from the spinnaker bow pole.

This multipurpose sail can be a perfect all-around first choice additional sail for cruisers or an essential powerhouse for racers. It is still a developing sail in many respects and offers some significant and worthwhile advantages.

It can be used very effectively to windward in light airs and for reaching in moderate airs. It thus eliminates the regular hank on genoa while providing more sail area, and it is easier to change headsails. The jib is just dropped and the screacher unfurled when required. Sheeting is to a simple strap around the aft beam which can be moved in and out for the correct sheeting angle.

For the best windward performance it is very important to keep the luff tight and many racing owners have even fitted 2 to 1 halyards to keep the clutch loads lower. However, the risk of twist when hoisting can then be higher and cruisers will usually not experience the sort of high loads that some hard racers can induce in the search for the ultimate performance.

The screacher can be tacked easily when needed by rolling up and then unrolling on the new side.

Note:

When you use your screacher the F-stay will become slack. It is important that when you return to sailing with the jib that the tension be eased off the screacher. That way the mainsail load will be transferred to the F-stay for better jib shape and performance. Or, you can lower the furled screacher along the wing net to reduce the weight aloft.



*All sails trimmed to work together*

## SPINNAKER

The spinnaker is a very easy sail to use on a trimaran, due to the wide beam and level sailing. The spinnaker thus becomes a very practical and safe sail for family sailing with very few control problems. All Corsair models use an asymmetric spinnaker which are the easiest to use, and the fastest if used correctly.

The asymmetric spinnaker can be launched from the leeward wing net, or main hull bow, and the sheets led back to blocks on the floats near the aft beams for general all round performance. For better pointing ability, particularly when tacking downwind, a closer sheeting angle is better, and the ideal position will vary depending on spinnaker. A block on a movable strap around the aft beam gives plenty of options in this regard.

The tack line is led from a block at the end of the pole back along the main deck to a cleat on the cabin roof at the aft end. To set, connect tack line, sheet, and halyard. Full on tack line until tack is at the end of pole, hoist and then sheet in.



*Racing with spinnaker*

## SPINNAKER JIBING

The asymmetric spinnaker can be jibed either through inside in front of the screacher or forestay or around the outside. With 'inside' jibing the sheets are run between the spinnaker tack and the screacher if fitted, forestay if not. Outside jibing requires the sheets to be run outside the spinnaker tack.

Inside jibing is probably the most common, as outside jibing does have the risk of a sheet going under the boat, though this is lessened using a continuous one piece sheet. The advantage is that the sail does not have to fit through the narrow slot between spinnaker and screacher.

With inside jibing, the skipper should start turning slowly while the crew eases the sheet to keep the sail full. As the clew nears the slot or the spinnaker starts to collapse, the new sheet should be quickly pulled in to pull the spinnaker through the slot and around while also releasing the old sheet.

The outside jibing procedure is similar with the crew waiting until the clew reaches just in front of the headstay and then pulling in the new sheet, with the sail going around the outside.

In all cases it is very important that the skipper turns slowly and then heads up to fill the sail before coming to the right course.

## SPINNAKER SAILING DOWNWIND

On first using an asymmetric spinnaker you may be

disappointed with downwind performance with a fixed mast-unless you take note of what is said here. The asymmetric cannot match a full symmetric spinnaker straight downwind because of the smaller, flatter area and a restricted ability to project to windward. The major advantage is considerably easier handling and superior reaching performance.

Tacking downwind does not work well with fixed masts, as the mast interferes with mainsail flow and the main is thus not very effective. A rotating mast is much more efficient and such boats can achieve a very large performance increase making downwind tacking the fastest way to go.

However, the same effect can be achieved with increasing sail area which helps smooth the flow over the mast and main with spectacular results.

The basic technique/rule is to sail downwind while keeping the apparent wind at about 90°, trimming the sails so they are not stalling or luffing. The jib for instance, should be sheeted to the float just aft of the forward beam. The extra speed generated will pull the apparent wind further forward allowing you to go deeper and deeper while maintaining a very high speed. Just keep the apparent wind at around 90°. It can be tricky to get the right angles, but if done correctly, the results can be exhilarating. So try it! Flying the jib inside the spinnaker may also help improve performance with a rotating mast in light winds.

## SAFE SAILING RECOMMENDATIONS

### DANGER

*Be fully aware that it is possible to capsize any multihull and the following rules should always be observed for safe sailing.*

1. Reduce sail early as follows:
  - a. Genoa/screacher should be replaced by jib with wind speeds greater than 12 knots.
  - b. Main should be reefed to first set of reef points when wind reaches 20 knots.
  - c. Main should be further reefed to second reef points when wind reaches 25 knots.
  - d. In winds over 35 knots main should be roller reefed to 4th batten from the top and jib replaced by storm jib.
  - e. With 50+ knots the main should be furled more, or completely, leaving only the storm jib.

If necessary, all sail can be taken off and a properly set up storm parachute anchor put out. This is now a well proven method for a multihull to survive even the worst offshore storm. It appears to virtually eliminate the

danger of capsize from both extreme wave action and hurricane force winds.

Other variations of the above are possible depending on the circumstances. Experienced and alert racing crews can delay reefing to even well beyond the above limits.

A quick way to reduce sail and achieve a very comfortable and safe motion is to simply drop the jib and sail under main only, reefed if considered necessary. This avoids the need to tack the jib and the fully battened main remains docile and easy to handle.

Sometimes when running downwind, it is better to drop the main and run under jib only. Corsair built trimarans can go to windward and tack while sailing under either jib or mainsail alone.

2. When winds are strong and gusty, and the boat is being sailed hard, then always have the sheet of the largest sail up, be it the mainsail, genoa, or spinnaker in hand, ready for quick release. Use only the camcleats provided and never use self-tailers as cleats in high winds-they are too difficult to release fast.

Always be ready to release the sheets if you feel the boat is being pressed too hard. Instruct your crew to do likewise. If concerned, then just reef until you are comfortable.



*This is definitely not safe sailing with a novice crew aboard!*

### DANGER

*Never leave the sheets unattended if un-reefed and the wind is exceeding 20+ knots.*

If being pressed while reaching, it is better to **bear away downwind** than round up. The boat will slow down and mast momentum from the turn is to windward, reducing heel. Round up and speed may increase surprisingly, while mast is thrown to leeward heeling the boat more.

The only time to luff up is while hard on the wind. Do not bear away in this case, feathering the sails until any gust passes by.



In general, your visual indication of being overpowered is when the leeward float is pressed far enough down to have waves regularly wash over it. If cruising with your family then you should reef before this happens for the best comfort. If sailing for speed then this is not of great concern, providing the crew is vigilant and this sort of sailing has been done for hours at very high speeds.

It is not unusual to drive the low resistance float bows through waves or even submerge the float in some circumstances. This has been found to have no adverse effect on the boat and in fact the boat will tend to round up slightly, not slew to leeward as commonly and mistakenly believed. However, this is sailing on the limit so don't push your luck unless prepared for a ducking.

3. Beware of being caught side on with little speed and with all sails sheeted in tight. This can happen after a tack if concentration is lost.
4. If caught in a severe thunderstorm, a simple safety procedure is to drop all sail and simply let the boat drift. You will lay side on to the wind which is quite safe unless the waves are very large, in which case you should steer off downwind. Corsairs will steer quite well from a reach to run with no sails up in winds over 5 knots - try it sometime. It is even possible to round up into the wind.
5. Another safety procedure in a severe storm is to simply drop all sails and anchor which is probably not used enough as a safety procedure. It is very effective. At sea a storm parachute anchor has the same effect.
6. Always listen to the latest weather forecast before you set out on any sailing trip.
7. Always leave yourself a large safety margin, be it while sailing or simply motoring around.
8. Always carry full safety gear, including life jackets as required by your country's Coast Guard and local regulations.



*For safety, always wear a life jacket when sailing hard.*

*Always keep the sheet in hand ready for instant release*

The above procedures will give a high margin of safety and should always be observed whenever safety is paramount. If absolute performance is required and an

experienced crew is aboard, the above limits can be comfortably exceeded. In some earlier sea trials, full sail has been carried in over 40 knots of wind including the spinnaker. This is not for the inexperienced however, and any skipper doing such sailing must be prepared for and accept the responsibility for the extra risks involved. It should not be done offshore.

## SAILING HINTS

Corsair trimarans have several unique sailing features, one of these being the ability to make continuous 360° turns in the one spot. To do this, while going to windward for instance, just tack, but don't touch any of the sheets. You will continue to turn, jibe and tack again indefinitely. This can be a handy tactic on starting lines!

A simple way of heaving is to just tack as above but immediately put the helm over to turn back into the wind with the jib sheeted on the windward side. This prevents tacking again and the boat will instead fall off. The rudder then takes over again and turns the boat back into the wind. You will then stabilize like this, just off the wind, moving forward very slightly. The helm can be lashed over and you now have a stable, barely moving work platform to do any needed repairs, stop for lunch or just wait for someone else to catch up!

Should you ever lose the rudder, for whatever reason, don't despair. Among the repertoire of tricks is the ability to sail without the rudder. It takes a little practice to get right and it is worth practicing sometime. Pull the rudder fully up (first making sure you have plenty of room). Now, to go to windward you sheet the jib or genoa as per normal but let the main right out. Pull the main on slightly and you will begin moving. Pull the main on and you will go faster, let it out and you will go slower. Pull the main hard on and you will tack. Immediately let it right out until you stabilize on a reach and then start pulling it in until you are going fast again.

This takes a bit of practice to get it right, and for a time you will be all over the place but after a while you should be able to work your way to windward, tacking too, just by adjusting the mainsail.

You can also sail surprisingly affectively without any sails. The mast alone is sufficient to get steerage way downwind and once moving you can bring her up on to a reach, even back into the wind. This can be a handy feature for coming into a ramp or dock at a greatly reduced speed.

Another feature is the ability to back up. This takes a bit of practice but by turning into the wind, and waiting until she starts going backwards, you can control this backing for as long as you want. Just steer the rudder whichever way you want to go. Can be useful in backing off a beach, or away from a dock - just let her go back, swing off a beach or away from a dock - just let her go back, swing around once in clear water, and then accelerate away.

The high potential speeds possible with rotating masts off the wind can be intimidating to new multihull sailors and, if necessary, the potential speed can be reduced to a more comfortable level by reducing sail or by under rotating the mast which depowers the mainsail. More rotation can be used as one becomes comfortable with the speeds possible.

When spinnaker running before very large seas offshore with boat speeds of 20 knots or more there can be a danger of pitch poling. This can be caused by pressure from the mainsail which cannot be caused downwind should the bow dig in. The solution is to drop the mainsail, which virtually eliminates this risk. This rule only applies to racers as cruisers should have reduced sail well before this even becomes a danger.

The limit for racers with modern rigs will always be nose diving, though this is hard to do with a Corsair design due to their characteristic 'high bow' sailing stance. The C28, for instance, at speed, frequently has the complete center hull bow section out of the water, the waterline beginning just in front of the dagger board. This comes from the wide flat swept up aft sections of the main hull which generate negative lift, actually sucking the stern down.

This characteristic can be maximized when needed with high speed racing downwind by moving the crew inboard and aft to the back of the cockpit. This keeps the flat aft sections of the center hull in the water and the bows very high by increasing the negative lift at the hull aft sections. This works most effectively on aft cockpit rotating mast boats, where the heeling component of the sails is less than the fixed mast, that being angled more forward.

Also important for the best performance, by minimizing wetted surface area, is to move crew weight well forward in light to moderate winds, to keep the bows down countering the stern negative lift.

The boat should also be heeled to leeward (crew on leeward side) when sailing to windward in light winds, just as with a mono. This keeps the sails in a more efficient shape.

## ANCHORING

Trimarans tend to be lively at anchor, due to their light weight and shallow draft. They like to sail from side to side, which can be annoying. This is simple to overcome by using a bridle setup to each float bow. These have eyes fitted as standard for a block to lead the bridle lines aft.

When anchoring, just lay out your anchor as normal, over the main hull bow roller. Set up the rope bridles running through the blocks on the float bows and back to the spinnaker coaming winches. Bring the 2 bridle lines together in the center of the boat and attach to the anchor line. Let the lines out further until they take over the load. You will then have a well behaved boat.

## BEACHING

One major multihull advantage is the ability to come right into a beach. You can either pull in far enough so that the boat cannot move around (which can wear out your expensive bottom paint) or anchor just far enough out so that the boat remains floating in 2 or 3" of water.

## RETRIEVING TO TRAILER

After sailing is finished, the jib is dropped and the mainsail is roller furled. Remember to lift the boom aft end as required with topping lift for smooth roller furling. Once fully rolled you should then furl the mainsail with one hand and reverse wind the boom with the other. This loosens the tightly rolled main, preventing any wrinkles and relieves any bending force on the battens.

The floats can be folded before arriving at the ramp for reduced beam and this also allows the float bows to be very useful step off points, if needed. Use the secondary wider folded position on the Cruze 970 if windy and there is still some distance to the ramp. Prior to folding, with all rotating masts, the mast raising wires must fitted.

### WARNING

*Rotating masts must be supported by raising wires before disconnecting shrouds or the mast could fall.*



*The advantages of a multihull with shallow draft can easily be seen.*

*Sometimes you don't even need an anchor, just pull up to the nearest beach*

Before folding, first check to see that no one is on the side being folded and then undo the beam bolts. The beams on the side first released may spring about 12" into the air as the last bolt is undone. Hold the top of the beam and lift upward to fold, taking care not to let the float swing in too fast against the center hull which could damage the stops. You will have to slow it slightly. Insert the beam locking pin. If the float does not fold in fully, the usual cause is the wing net catching on the aft corner of the cabin side rail. To correct, just push the wing net down under the cabin side rail.

#### WARNING

*Take great care while folded in wind of 25 knots or more. A combination of a high cross wind and a fast, tight turn, may be sufficient to overcome the folded stability of bigger designs resulting in a roll over.*



Beam locking pin: 750/C28/Cruze 970

Now fold the second side. You may find this initially more difficult. As the boat is heeled this way due to the first float folded lifting that side. Crew weight on the already folded side will help by leveling the boat out more. Lift, and once again don't let the float come in too fast once it starts moving. Insert the beam locking pin.

If anything seems hard or difficult when folding, stop and see if anything is misaligned or snagged. A common error is to try and fold without disconnecting the shrouds. The beam won't budge, so remember to check this.

Raise the dagger board and rudder and cleat both in the up position. You are now ready for the trailer.

If there is a cross wind at the ramp then a side guide rail should be fitted to the leeward side of the trailer. This will prevent the boat swinging sideways and off the trailer.

Back the trailer down into the water until the water reaches the forward inward bend of the trailer but not any further than this. Gently guide the boat into the center and pull up as far as it will go. Take care here that it comes on straight and avoid pulling it over the Log paddlewheel sender unit on the bottom of the hull (gets expensive to replace).

A side line from the windward aft cleat may also be helpful if cross winds prevent the stern swinging too far sideways.

If motoring onto the trailer, leave the dagger board down until the last minute otherwise any crosswind makes it very difficult to keep on center. Once fully

on, connect the trailer winch hook and winch on the remaining few feet.

The boat can now be pulled from the water and when on level ground, remember to check that it is fully winched slack in the winch wire. Tie an extra safety line from the bow eye down to the winch post, ready for de-rigging.

## DE-RIGGING

Remove the bow line, separate the two lines, and use as the side tie - downs. Fit aft mast support and the trailer lights.

Remove the jib and fold. The jib sheets can be stowed in the anchor well ready for instant use next time. If possible the jib can be stored inside one of the floats - thus keeping it from cluttering up the main cabin.

If possible, relieve the tension on the battens and these can be left in the loosely rolled main. Remove the roller furling handle (if fitted) and stow in the anchor well. Leave the topping lift on to take the weight and disconnect boom from the mast. Lay it down on the cabin roof to one side and fit the sail cover/bag. Disconnect the topping lift and reconnect to the mast.



Use the topping lift to fit/disconnect the boom

The boom/mainsail is heavy on the C28 and Cruze 970 and hard to handle. It can be stowed in the cabin if you wish, but this takes considerable effort and room inside. It is much more convenient to stow it on the cabin roof where it is protected by its bag and is ready for instant use next time.

To lower the mast, release the jib halyard from the rope clutch, turning block and mast base block (if necessary) and cleat it to a horn cleat on the mast side. Release the trailer winch hook, pass it over the bow roller and hook to the jib halyard. Tension the winch until the forestay just becomes slack, allowing the pin to be removed. There is no need to slacken the turnbuckle.

Take the forestay back and secure to the mast. Remove all halyards etc. from the rope clutches and blocks as required. Wrap these around the mast to retain all stays and halyards neatly against the mast. It is important that this is done now, otherwise when lowering the mast

any loose stays will tend to fall away over the boat. It also makes subsequent rigging easier.

Fit the mast raising pole/yoke assembly and begin lowering the mast by letting out the trailer winch line. The raising wires must be fitted with rotating masts. As the mast comes down take care that the winch line meets the center of the raising pole, and that the mast is central when it reaches the aft mast support.

### CAUTION

*If your trailer winch does not have an automatic brake feature, don't let go of the winch handle while lowering. Should this happen it will start spinning very fast and could cause injury. Don't try and stop it, except by using the winch brake. Don't try and grab the handle! You will just have to let the mast fall, it's better than a broken hand.*

Once the mast is fully down, disconnect the winch hook, reconnect to the bow eye, and retention. The jib halyard is then reconnected to the mast.

Disconnect mast from the step and lift it up to enable the wind indicator to be removed from the masthead. Walk the mast forward until the mast can be mounted on the pulpit's lift up spigot (in roller furling shaft hole) or rested on the carrier on the pulpit.

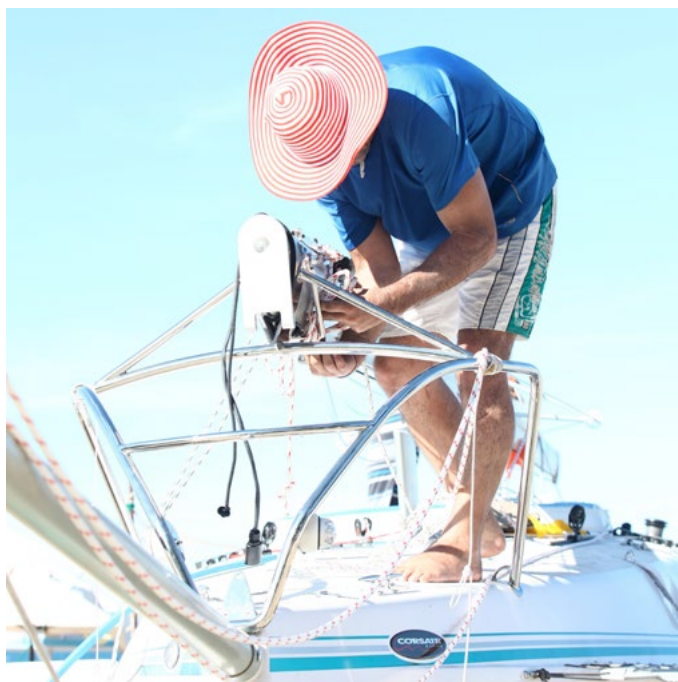

Mast carrier on pulpit 750

Secure the mast to the pulpit and aft mast support. All rigging wires and stays should now be secured to the mast. This is to prevent them from rubbing on the deck which will quickly wear through any gel coat or paint. On long trips it is also a good idea to pad between the wires and the mast or remove the wires altogether.

### CAUTION

*Do not use elastic cord type ties on the mast with hooks as they can be dangerous by whipping back and causing eye damage.*

Rudder should be fully up and tied to one side. Should local regulations not permit the rudder to be left on the transom, it should be removed and stowed in the towing vehicle. If fitted, secure the pop top down or it could lift up during high speed towing.

Connect the trailer lights (making sure they are on the correct sides) and then check that the trailer is correctly positioned under the hull. You are now ready for the road.

### LIFTING OUT

Should there be no ramp present then all Corsair models can be quite safely lifted in and out by the usual dockside lift, using the optional and permanent lifting Eyes.

Slings can also be used around the complete folded craft, the best bearing areas for the slings being the beam areas. Other temporary lifting points are the mainsheet traveler (outer corners), shroud chain plates on the center hull (when fitted), or the beam bolt pads in the beam recesses.

### MARINA DOCKING

For marina docking, the shrouds are released from the floats and the floats folded as normal. The marina slip can then be entered and the folded boat moored as with any other craft. However, care must be taken if high cross winds are a possibility, as folded stability is limited. Precautions include running a line from the mast to the dock on each side, a wider folded position, or lowering the mast in extreme conditions. Folded stability without the mast is very good and the folded boat can actually self right up to even an 80° to 85° heel angle.

One problem with marina docking is stains or growth on the lower float sides. This is not a major problem with short stays in a slip, but will be a nuisance over a long period. There are several ways to overcome this, one being the use of an antifouling wax on the float sides. Thus the gelcoat finish is preserved and only an occasional wipe is needed. Antifouling paint could also be applied to the float sides but this is not attractive, it needing to be 2' 6" wide.

One of the best and recent solutions for long term marina docking is a dock liner, which surrounds the boat with sterilized water, preventing growth.

### SAFETY

The modern trimaran with its enormous stability and unsinkability is a very safe craft and has now

established an excellent safety record. However, this safety is dependent on the operator and how the craft is handled.

The major hazard to be avoided is capsizing. This is rare with well sailed cruising multihulls but can occasionally occur with racers pushing it to the limit. Sail too fast for the conditions and the risk of capsizing is higher.

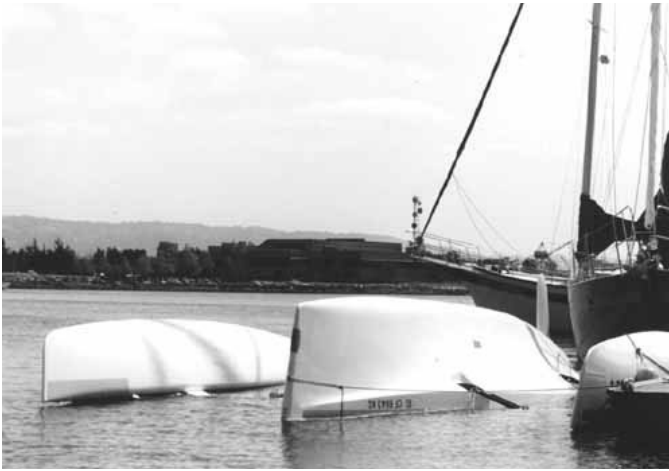

*Push it too far, this is what may happen - note how high it is floating, the water level being around the bottom of the beams. Even in this position it remains a relatively easy and safe boat to move around on.*

In general, the risk factor will only begin to increase when boat speed exceeds 15 knots while reaching or about 10 knots windward. When sailed for the conditions, or with safety in mind, Corsairs are the safest craft afloat.

## UNSINKABILITY

This is the ultimate safety feature for any boat. All Corsair models are unsinkable being constructed almost completely in foam/glass with multiple watertight compartments. With no heavy keel, it is therefore immune from sinking, even with all watertight compartments flooded.

There are up to 12 watertight compartments depending on the model, including:

Floats: 3 compartments each

Forward berth: an important factor against collision

The four beams: up to 170lbs buoyancy each

## OFFSHORE SAILING

All Corsair models have been designed strong enough for heavy weather sailing; the C28, C31, C37 and Cruze 970 have now crossed both the Atlantic and Pacific Oceans many times. However, it should be noted that they are small boats for such long offshore passages and should only be undertaken by experienced sailors and well prepared vessels.

Due to the considerable wear and tear that can result from such voyages and the many unforeseen hazards, warranty coverage is not available for any boat undertaking any passage offshore longer than 200 miles.

\*\*\*\*\* WARNING \*\*\*\*\*

THE SAFETY OF ANY CORSAIR MODEL AT SEA CANNOT BE GUARANTEED AS OFFSHORE SAILING CAN BE A HAZARDOUS UNDERTAKING WITH MANY RISKS. NUMEROUS FACTORS BEYOND THE CONTROL OF THE MANUFACTURER WILL AFFECT THE SAFETY OF ANY OFFSHORE VOYAGE AND ANY OWNER TAKING A CORSAIR TRIMARAN OFFSHORE MUST ACCEPT FULL RESPONSIBILITY FOR ANY RISKS INVOLVED.

It is not within the scope of this manual to go into all the necessary equipment for offshore sailing, this being covered by many readily available books, and/or offshore safety regulations. Essential items are an under wing re-entry hatch, the optional storm jib and a properly set up storm parachute anchor. The parachute anchor is a recent development for multihulls and offers a very comfortable and safe method for surviving severe storms.

## CAPSIZE

Capsize is always a possibility even if a remote one and should it ever occur, stay calm and make sure all crew are accounted for. Anyone inside can stay there, it being safe for some time. There is no danger of sinking.

When sailing offshore the following items should always be stored in the safety compartment (accessible from underneath if capsized) with lanyards attached and in watertight bags:

- EPIRB unit
- Cutting tools
- Extra wrenches & tools
- Bolt cutters
- Spare beam bolt wrench
- Ropes
- VHF hand held radio
- Pliers
- Copy of righting instructions
- Flares

Surge is the major enemy inside the boat and the first priority should be to seal all hatches, vents etc. and try to keep the boat dry as possible. The pop top will remain in place as this will try to float upwards. Main battery switch should be turned off and all loose objects stored in the cabin settees, these now being above water. Surge will otherwise remove everything. Water level while inverted is around the bottom of the beams - float decks are only just immersed.

If possible, the battery should be removed as it will discharge under water. It should be in a sealed unit thereby eliminating the danger of acid or gas.

If offshore, the crew outside can use the recommended re-entry hatch to shelter inside.

You now have a large, relatively comfortable life raft and well stocked with provisions, much better off than in a small life raft with minimal provisions. In fact the record for the longest survival time adrift at sea is now held by the crew of a trimaran capsized off New Zealand in 1990. They were in such good condition when rescued that their story was first believed to be a hoax.

## RIGHTING

Righting at sea, unless outside help is available, is probably not a feasible option as yet. Probably better to leave the craft as it is, where the crew are safe and wait rescue.

When the opportunity arises and outside assistance is available, the most successful system for any multihull, is to tow the capsized boat fore and aft. Depending whether the stern or bow is lower in the water will determine where you attach your tow line bridle, so make sure you choose the end that is floating highest.

You may need to use a second bridle line and attach this to the beams that are closest to the tow vessel (see Dia). These lines will prevent the vessel slewing off line as you right the vessel. As you begin to right your vessel you will need to ease these lines.

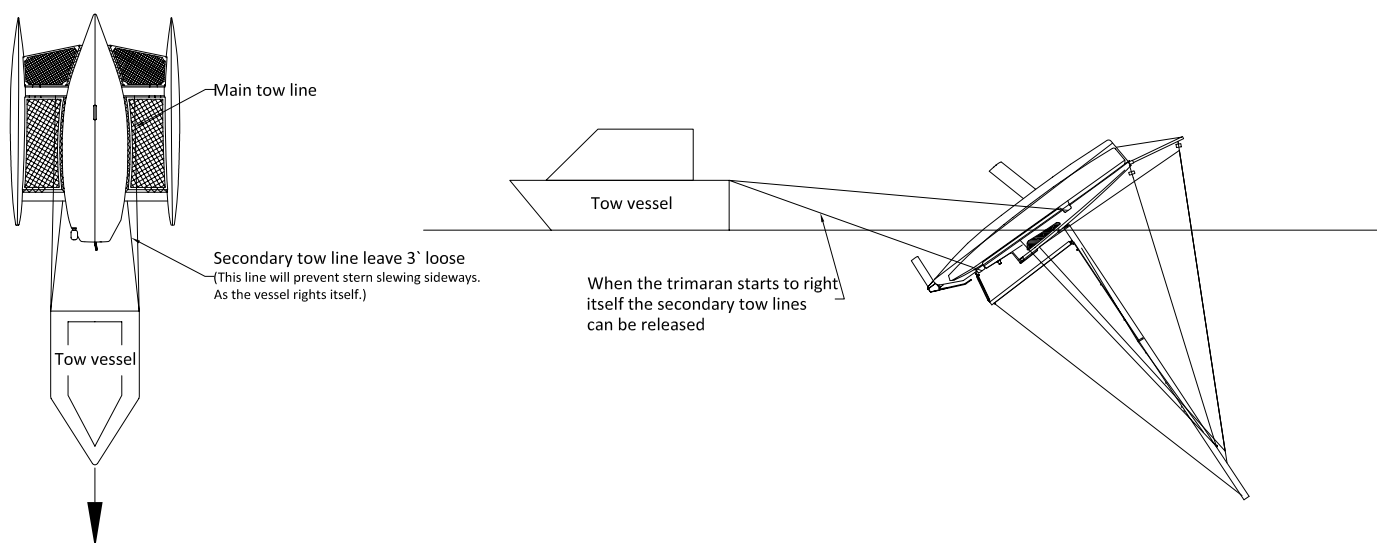

*Righting Procedure*

If the above procedure does not work, then try flooding the end that needs to sink, or add some crew weight (ready to abandon ship once the end concerned starts to go under). If this fails, try towing the other direction. Some controlled flooding may also be required. Towing sideways will not work.

Righting your vessel using the following folding system is as follows:

1. Put on a lifejacket this is essential for easy working in the water.
2. The boat will be floating side on to the waves and you should first attach righting ropes to the windward float beam areas and bring them over the main hull to the leeward float. Use a pair of lines for each available crew member.
3. Disconnect and save both shroud tensioners if fitted which can then be used to help as necessary.
4. Release top shrouds from the float chain plates and allow to drop with fixed masts. Secure a line from the leeward shroud with rotating masts to the leeward float.
5. Connect a line to the forward beam area on the leeward float and connect this to righting line from the other side using 4:1 shroud tensioner.
6. Release all beam bolts. This can be done while alongside without diving. The bow nets may have to be unlashed to reach forward beam bolts.
7. Stand on the wing net and pull on the shroud tensioner. The float on the side you are standing on will fold up, your weight helping. Once folded, insert the beam locking pins. Repeat process with other side float. Smaller

designs will fold up just from your weight on the wing net.

You now need to drop the mast off, and use its weight to assist righting by helping the hull to rotate in the direction desired. This is done by hanging it from a line passing over the leeward float and attached to the windward float.

If in sheltered waters, damage to mast can be minimized by pulling back to the trailering position. However, outside assistance will probably then be needed to rotate the boat.

8. Release the forestay, attach a line and take to the center of the leeward float. Run the line over the center hull to attach to the windward float deck eye just in front of the deck hatch.

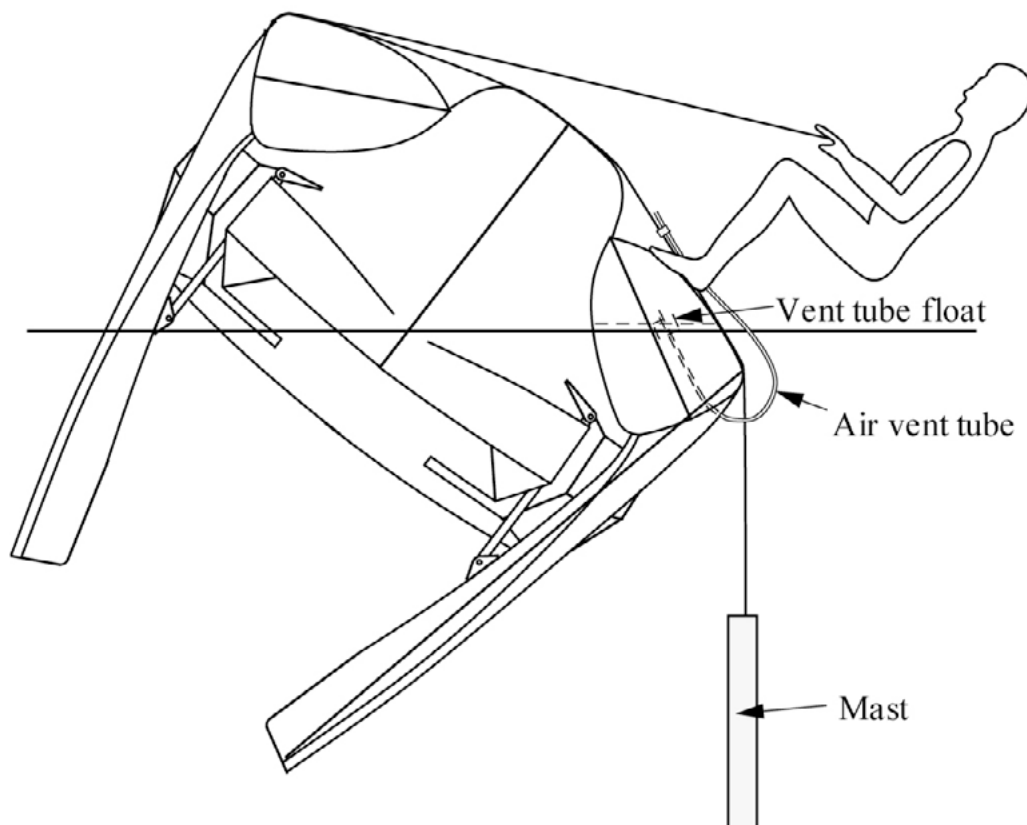

*Last option righting method*

9. Release all halyards from the rope clutches, and unthread from the turning blocks.
10. Release mainsheet from traveler, the jib sheets, jib tack, inner forestay (if fitted), and any remaining shrouds.

The mast will now drop, or hang from the step pivot pins with fixed masts, which will soon break from the motion of the deck pivot brackets from inside. Mast will now hang from the leeward float.

11. Open all hatches on the leeward float and stand on the float stabilizing yourself with the righting ropes, to the windward side. The float will slowly start to flood. If necessary small holes may be required on the highest part of the float side to let out trapped air, or a simple vent tube from this area to the atmosphere will allow the air out.
12. As the float floods, start rocking back and forth in time with the waves. Once the float is flooded sufficiently, the boat should roll upright. It's possible to climb around the boat as it rotates to end up on deck. The beam retaining pins will fall out and floats will tend to unfold themselves.

Now tighten the beam bolts, and start bailing. A long tubular type bilge pump is needed to do this successfully. You may initially need to wrap a rag or towel around its body where it enters the circular float hatch to prevent water reentering. Pump should always be secured so that it cannot float away.

If you find your weight is insufficient to cause righting, then additional weight such as the outboard motor or battery can be sent down the mast line to assist. If assistance is available, then a tow sideways tow will work.

The mast may or may not be salvageable depending on the number of crew available.

## PERSONAL RESPONSIBILITY

There have been exhaustive efforts to minimize the risk of personal injury, loss, or any other form of damage, while operating a Corsair built trimaran but obviously it is impossible to completely eliminate every risk. Winches cannot be made trip proof, nonskid can wear and cause slipping, rigging wires can be kinked while rigging and later fatigue, lifelines can be fallen over, frequent groundings at speed can cause eventual dagger board or rudder failure, neglect of proper maintenance can cause early failure and lack of experience can cause accidents in congested areas or bad conditions. Sailing can be hazardous at times and the boat operator should accept responsibility for all such hazards.

Many of these risks have been covered in this manual, but obviously it is impossible to cover them all. Some recommended procedures may not even be the correct ones in certain situations. The operator should therefore always be vigilant against all possible safety hazards and correct or warn the crew against any possible danger immediately.

## SAFETY IN GENERAL

Capsize matters can be depressing but to put it in perspective, a capsize is simply very difficult to do. Luffing up slightly or bearing away (if on a reach) is usually all that is required. The risk of capsize can be virtually eliminated simply by reducing sail according to the conditions and being prepared to let the sheets go.

When under spinnaker in winds of over 20 knots it should always be a matter of policy to never leave the spinnaker sheet unattended. It should be hand held, not even cleated. Cruisers shouldn't even use the spinnaker in over 20 knots. Under main and jib you can still reach 15 knots, with complete comfort and safety.

Fortunately it is very hard to capsize a Corsair trimaran but this can lead to overconfidence. Don't fall into this trap! Always be aware that it is possible to capsize and reduce speed accordingly to suit the conditions - just like any car.

## TECHNICAL NOTES

### WINCH LINE

The trailer winch line should be regularly replaced. This tends to wear quite rapidly and is under a high strain when lifting the mast. A breakage here could be very dangerous. It is always advisable to stand clear of the line while lifting the mast. Also, frequently check the trailer winch line tight when on a long trip.

### SPRING RETAINING CLIPS

**CAUTION:** The spring retaining clips as used on the turnbuckle clevis pins should be regularly checked to ensure they will still 'clip' fit on the clevis pin. Replace if they have lost their spring and become loose, otherwise you could lose your mast.

These spring clips have been used successfully for over 20 years and are intended as a convenient 'quick rig' feature. They are not as secure as a properly fitted cotter pin, and if any doubts exist on their use then a cotter pin or circular ring should be used instead and a few of these are usually included in the toolbox. However, these rings or pins will increase rigging time and the final decision in this regard is for the owner.

### LAUNCHING

If immersing the trailer to the bend in the frame will still not let you free the boat, be careful; a few inches more can have your boat drifting away so have a bow line secured.

### BEAM BOLTS

These should always be in place and tightened before going sailing. Otherwise the upper folding struts can again be overloaded as above due to the beam inner end being forced up slightly by sailing loads.

It is also possible, but unlikely, for a beam bolt to gall and seize in a bolt pad, which can prevent you from folding up the boat. If this happens, then you can still fold up the boat by simply releasing the bolt pad nuts from inside or cutting off the Beam bolt head. To avoid this, keep the threads well lubricated with Teflon grease.

### HOISTING MAINSAIL

If you find this is tight going up or down (a not uncommon problem with full batten boltrope mains) there are now some spray-on silicon compounds that can help. Remember to also check that the mainsail foot outhaul is slackened off.

### BEARING AWAY

Don't forget this is a very effective and safe way of absorbing gusts while reaching in strong wind conditions, particularly under spinnaker. Rounding up tends to throw the mast to leeward (the wrong way) and can increase speed dramatically - all very exciting. However, bearing away throws mast to windward, speed falls off and the motion feels much safer. This may sound odd, but try it sometime in lighter conditions to get confidence - it really works.

### HEAVY HELM

The tiller should always be light and easy to handle with just one hand. If not, then there is something wrong. Usual cause is the rudder blade has kicked back slightly. If this is not the problem then rudder may not be raked far enough forward. This can be changed by filling the pivot hole in the rudder blade and re-drilling slightly further forward (say ¼").



## RUDDER/DAGGERBOARD HUM

This is not an uncommon occurrence due to the difficulty in getting perfectly fair foils in a production environment, and even carefully handmade foils can develop a hum. This can be reduced or eliminated with a little fine tuning by filling or sanding the trailing edge of the foil concerned.

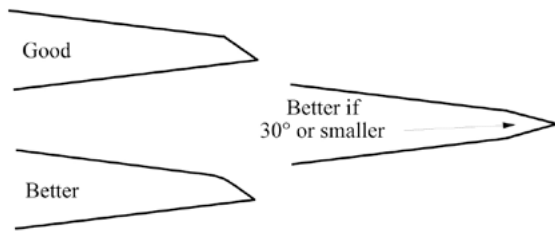

## RUDDER VENTILATION

This can be a problem at very high speeds, and symptoms include a 'whoop' sound out the back, a huge rooster tail, and no steering. This normally only happens with speeds over 15 knots and fortunately the boat usually just keeps tracking straight.

The cause is air being sucked down the side of the rudder at high speeds, particularly if over steering. Immediate cure is to waggle the rudder a little or bring onto the centerline until the water flow reattaches or to slow down.

To avoid, always keep the leading edge of your rudder smooth and fair, and if it becomes a consistent problem then the best cure is to fix a horizontal 'fence' to the leading edge of the rudder about 12" to 15" up from the bottom.

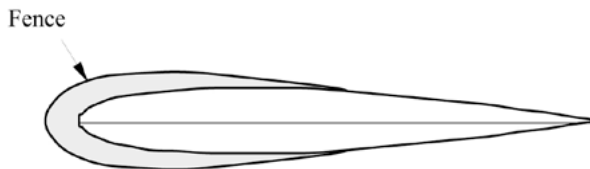

*Rudder ventilation solution*

This will prevent the air from traveling down the blade and retains steering control even if the top part of the rudder has ventilated. Such fences are fitted as standard on some higher performance models.

## COMPRESSION PADS

These are fitted to the ends of the beams on all Corsair models to eliminate any gap or movement between the beam ends and the raised pads in the hull.

Do not remove, as this would cause the high compression loads in this area to be directed through the upper folding struts which, in the case of the C24 and C31 are not strong enough for such loads. They are designed for folding loads only and end mounting points may fail.

This would not cause a serious beam problem as the beams then simply move inboard to bear against the hull again. The boat is not threatened structurally; however repairing a U.F.S. mounting point is difficult and expensive.

The plastic compression pads should be full width of the beam and bear evenly against both beam and hull to avoid any point loading. This should be checked periodically.

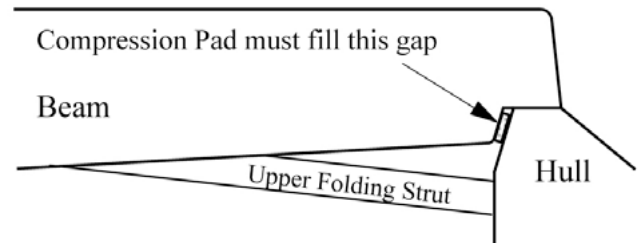

*Position compression pads*

The C28 has similar pads on the forward beams but these are not structurally important, their only purpose being to eliminate any movement for better rig stiffness.

## WING NETS

Take care that you do not step near the inner ends of the nets on the sides where lashing cannot be used in order to allow easy folding. Your foot may go through this gap. This area can be lashed if you wish but should you forget to undo when folding, the eyelets in the nets will be pulled out.

## FLOAT/BEAM VENTS

The floats are vented through micro cowl vents fitted to the float transoms (or spring loaded vents just aft of the forward beams on earlier models). These are to prevent a buildup of air pressure inside the floats on hot days that could be enough to open up the hull to deck join.

The watertight bulkheads at the forward beam and shroud chain plate bulkheads thus have very small holes near the top to allow venting throughout the float. Should the float ever be holed then these should be well above the flooded waterline, or at worst, only allow a very small amount of water through.

Should the float be inverted as in a capsize, then the airlock formed above these vents would prevent any significant flooding.

Hollow beams such as used on the C28 also need draining/venting and this is done through tubes extending from the bottom of the beams inside the floats. Should water appear from these then the source of the leak in the beams should be investigated and repaired.

In the case of capsize, these tubes are designed to extend above the floats flooded waterline so as to prevent any water entering and consequent loss of beam buoyancy.

## RUST

Many grades of stainless steel will get an occasional brown stain saltwater that can look like rust. The grade used on most marine fittings is Type 304 or 303 and both of these will show this. Type 316 which is a more expensive grade but actually slightly weaker, does not. All three grades can be used on a Corsair, depending on the application. To avoid this staining, always wash your boat down with fresh water after every outing. The brown stains will not appear if the salt is washed off.

## CLEANING FLOATS

These can be extended for cleaning, if wished, while boat is on the trailer. Float supports must be dropped down and the boat then rocked one way. The 'high side' float can then be extended. Let the boat lean the other way and the remaining float can be extended. You will need to support the floats in some way once extended.

## CLEAN BOAT HINT

If you are having problems with non house-trained birds on your boat, just leave a dummy, but lifelike snake in the cockpit floor. Works well!

## COLLISION

Any boat that has a significant fore and aft collision on the float bow or the folded beams have hit a low bridge, should always be thoroughly checked. No boat can be made collision proof and hidden damage can result.

The complete float should always be checked after an impact, not just the bow area. A heavy fore and aft collision can actually propagate throughout the float and has even generated cracks around the aft deck inspection hatch flanges for instance. In one case, a float hull had a vertical fracture in the aft beam area from a severe bow collision.

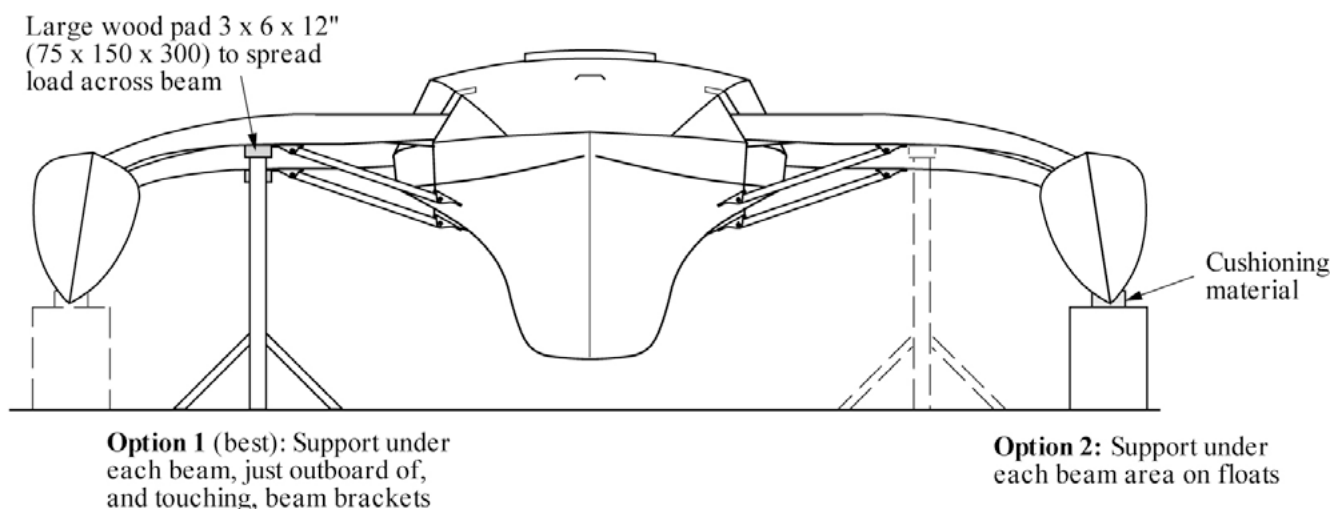

*Support for maintenance. When necessary, the craft can be supported for short periods as detailed above for anti-fouling or other maintenance work*

The beams should also be carefully checked if they have received any significant sharp impact. Being carbon fiber, they can be cracked or damaged from sharp impacts and areas to check are around the lower folding strut brackets and just inboard from the float. Even if no damage is found, continue to monitor for cracks over a period of time. The diagonal wire braces as used on the Cruze 970 and C37 tend to direct shock loads into the forward beam structure in this area. Any cracks in this flange should be investigated and repaired.

The forward beam bulkhead to hull join tape just adjacent to this flange area on the 31 should also be investigated closely as this is a known failure point from such collision. Damage here may not be visible initially, but it may grow to eventually fail later, so continue to monitor. The boat still holds together should this tape delaminate, but obviously sailing should cease until it is repaired.

## HURRICANE SURVIVAL

Hurricanes frequently cause damage to many boats and on one occasion capsized a folded F-27. The owner had left it on a mooring and being worried about possible damage from other boats breaking their moorings nearby felt it best to fold her up to reduce the 'target' profile. However this considerably reduces stability and as stated earlier, this is limited while folded. As a result, no doubt while swinging sideways, the gale force winds blew the F-27 on its side.

The best procedure in such a situation is to get the boat out of the water and trailer it inland away from harm - the perfect solution and used by most owners. If there is not time for this then leave the floats extended and pump water into each float and the main hull to weigh her down. Also remove the wing and bow nets. These don't have much windage, but it is surprising how much it can be in such winds. Your boat is then as safe as anything can be in a hurricane.

## SPECIFICATIONS

The following specifications may vary depending on options and manufacturing or design changes.

### C24 MK II

L.O.A.:	24' 3"	(7.3m)
L.W.L.:	23' 7"	(7.2m)
Beam:	17' 11"	(5.5m)
Beam folded:	8' 2"	(2.49m)
Draft (hull only):	1'	(0.31m)
Draft D/B down:	4' 5"	(1.36m)
Mast length:	31' 10"	(9.7m)
Weight:	1690lbs	(770kgs)
Max. recommended auxiliary: 8 hp		

### Sprint 750 MKII

L.O.A.:	24' 3"	(7.39m)
L.W.L.:	23' 7"	(7.19m)
Beam:	17' 11"	(5.46m)
Beam folded:	8' 2"	(2.5m)
Draft (hull only):	1' 00"	(0.3m)
Draft D/B down:	5' 3"	(1.6m)
Mast length:	34' 5"	(10.5m)
Weight:	1,795lbs	(816kgs)
Max. recommended auxiliary: 8 hp		

### Dash 750 MKII

L.O.A.:	24' 3"	(7.39m)
L.W.L.:	23' 7"	(7.19m)
Beam:	17' 11"	(5.46m)
Beam folded:	8' 2"	(2.5m)
Draft (hull only):	1' 00"	(0.3m)
Draft D/B down:	5' 3"	(1.6m)
Mast length:	34' 5"	(10.5m)
Weight:	1,925lbs	(875kgs)
Max. recommended auxiliary: 8 hp		

### C31 UC/CR

L.O.A.:	30' 10"	(9.4m)
L.W.L.:	30' 0"	(9.15m)
Beam:	22' 5"	(6.8m)
Beam folded:	8' 3"	(2.5m)
Draft (hull only):	1' 4"	(0.4m)
Draft D/B down:	5' 6"	(1.7m)

Mast length:	42' 6"	(13m)
Weight:	3,850lbs	(1750kgs)
Max. recommended auxiliary: 20 hp		

### C31 RS

L.O.A.:	30' 10"	(9.4m)
L.W.L.:	30' 0"	(9.15m)
Beam:	22' 5"	(6.8m)
Beam folded:	8' 3"	(2.5m)
Draft (hull only):	1' 4"	(0.4m)
Draft D/B down:	6' 6"	(1.84m)
Mast length:	42' 6"	(13m)
Weight:	3,700lbs	(1680kgs)
Max. recommended auxiliary: 20 hp		

### Cruze 970

L.O.A.:	31' 10"	(9.7m)
L.W.L.:	31' 10"	(9.7m)
Beam:	22' 7"	(6.88m)
Beam folded:	8' 4"	(2.55m)
Draft (hull only):	1' 5"	(0.45m)
Draft D/B down:	6' 10"	(2.1m)
Mast length:	39' 4"	(12m)
Weight:	3,999lbs	(1,814kgs)
Max. recommended auxiliary: 20 hp		

### C28 RS

L.O.A.:	28' 5"	(8.7m)
L.W.L.:	26' 3"	(8.0m)
Beam:	19' 9"	(6.1m)
Beam folded:	8' 3"	(2.5m)
Draft (hull only):	1' 2"	(0.36m)
Draft D/B down:	4' 11"	(1.5m)
Mast length:	38' 00"	(11.6m)
Weight:	2,900lbs	(1315kgs)
Max. recommended auxiliary: 15 hp		

### C28 CR/CE

L.O.A.:	28' 5"	(8.7m)
L.W.L.:	26' 3"	(8.0m)
Beam:	19' 9"	(6.1m)
Beam folded:	8' 3"	(2.5m)
Draft (hull only):	1' 2"	(0.36m)
Draft D/B down:	4' 11"	(1.5m)
Mast length:	36' 6"	(11.1m)
Weight:	3,100lbs	(1400kgs)
Max. recommended auxiliary: 15 hp		

### C37 CR

L.O.A.:	37' 0"	(11.27m)
L.W.L.:	35' 0"	(10.66m)
Beam:	25' 7"	(7.8m)
Beam folded:	9' 10"	(3.0m)
Draft (hull only):	1' 8"	(0.5m)
Draft D/B down:	7' 7"	(2.3m)
Mast length:	51' 2"	(15.6m)
Weight:	6,700lbs	(3050kgs)
Max. recommended auxiliary: 20 hp		

### C37 RS

L.O.A.:	37' 0"	(11.27m)
L.W.L.:	35' 0"	(10.66m)
Beam:	25' 7"	(7.8m)
Beam folded:	9' 10"	(3.0m)
Draft (hull only):	1' 8"	(0.5m)
Draft D/B down:	7' 7"	(2.3m)
Mast length:	51' 2"	(15.6m)
Weight:	6,300lbs	(2850kgs)
Max. recommended auxiliary: 20 hp		

## CORSAIR SAIL PLANS:

### C24 MKII sail plan

#### NOTES:

Mylar may be used for all sails (recommended).

Sailcloth wgt. to suit wind in area sailed.

All sails are to be fitted with telltales

Max. roach is 41"/1040mm located 60% up leach

Mainsail has 2 sets of reefpoints

Mainsail to have Cunningham eye fitted

Class emblem to be as shown.

Jib to have 3 leach battens placed at equal distance on leach.

Jib hanks to be for 1/4"/6mm wire

Sail	Luff	Leach	Foot	Area
<b>Mainsail</b>	29' 6" 9000	30' 6" 9300	11' 6" 3500	243sq.ft. 22.5sq.m.
<b>Blade Jib</b>	27' 8" 8445	24' 6" 7475	9' 9" 2960	122sq.ft. 11.3sq.m.
<b>Asymmetric Spinnaker</b>	33' 2" 10100	26' 11" 8200	20' 8" 6300	570sq.ft. 53sq.m.
<b>Screacher</b>	30' 10" 9400	24' 6" 7475	15' 5" LP 4700	243sq.ft. 22.5sq.m.



# Sprint 750 MKII sail plan

SAIL AREAS AND DIMENSIONS				
SAIL	LUFF	LEECH	FOOT	AREA
MAIN	9750 32'	10110 33.17'	3250 10.66'	24.87sq.m. 268sq.ft.
#1 JIB [See *]	8760 28.74'	8030 26.35'	2780 9.12'	13.3sq.m. 143sq.ft.
SCREACHER	9820 32.21'	8840 29'	9480 31.10'	24.33sq.m. 262sq.ft.
SPINN'R	11470 37.63'	9490 31.14'	6590 21.62'	57.65sq.m. 620sq.ft.

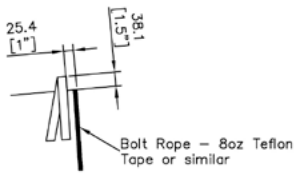

HEAD DETAIL

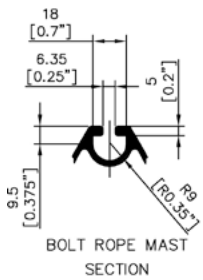

BOLT ROPE MAST SECTION

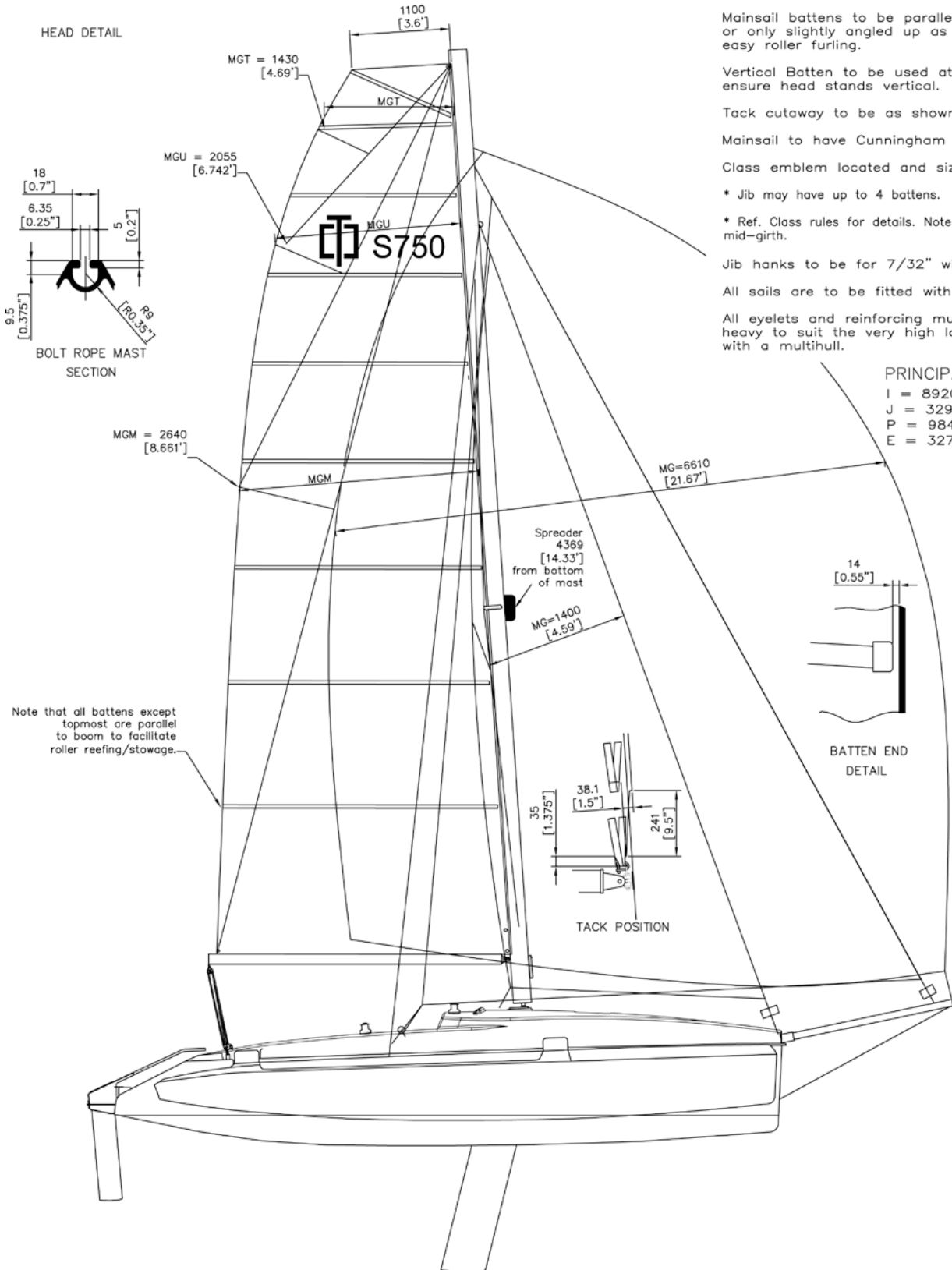

Note that all battens except topmost are parallel to boom to facilitate roller reefing/stowage.

**NOTE:**

Square Top Mainsail as shown is required to be Class legal.

Mainsail battens to be parallel with boom or only slightly angled up as shown for easy roller furling.

Vertical Batten to be used at head to ensure head stands vertical.

Tack cutaway to be as shown.

Mainsail to have Cunningham eye fitted.

Class emblem located and sized as shown.

\* Jib may have up to 4 battens.

\* Ref. Class rules for details. Note specified mid-girth.

Jib hanks to be for 7/32" wire.

All sails are to be fitted with telltales.

All eyelets and reinforcing must be extra heavy to suit the very high loads possible with a multihull.

**PRINCIPAL DIMENSIONS**

- I = 8920 [29.27']
- J = 3290 [10.8']
- P = 9840 [32.3']
- E = 3270 [10.75']

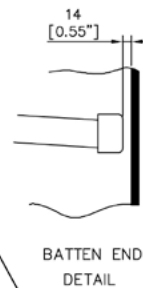

BATTEN END DETAIL

# Dash 750 MKII sail plan

SAIL AREAS AND DIMENSIONS				
SAIL	LUFF	LEECH	FOOT	AREA
MAIN	9750 32'	10110 33.17'	3250 10.66'	24.87sq.m. 268sq.ft.
#1 JIB [See *]	8760 28.74'	8030 26.35'	2780 9.12'	13.3sq.m. 143 sq.ft.
SCREACHER	9820 32.21'	8840 29'	9480 31.10'	24.33sq.m. 262 sq.ft.
SPINN'R	11470 37.63'	9490 31.14'	6590 21.62'	57.65sq.m. 620 sq.ft.

**NOTE:**

Square Top Mainsail as shown is required to be Class legal.

Mainsail battens to be parallel with boom or only slightly angled up as shown for easy roller furling.

Vertical Batten to be used at head to ensure head stands vertical.

Tack cutaway to be as shown.

Mainsail to have Cunningham eye fitted.

Class emblem located and sized as shown.

\* Jib may have up to 4 battens.

\* Ref. Class rules for details. Note specified mid-girth.

Jib hanks to be for 7/32" wire.

All sails are to be fitted with telltales.

All eyelets and reinforcing must be extra heavy to suit the very high loads possible with a multihull.

**PRINCIPAL DIMENSIONS**

- I = 8920 [29.27']
- J = 3290 [10.8']
- P = 9840 [32.3']
- E = 3270 [10.75']

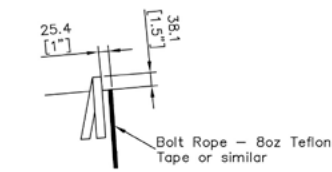

HEAD DETAIL

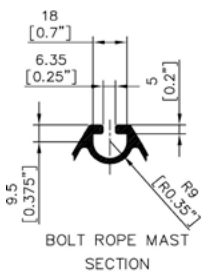

Note that all battens except topmost are parallel to boom to facilitate roller reefing/stowage.

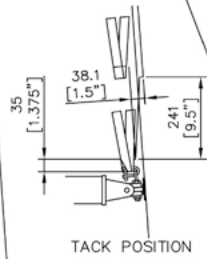
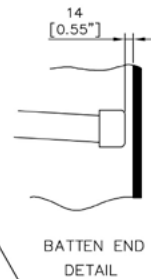
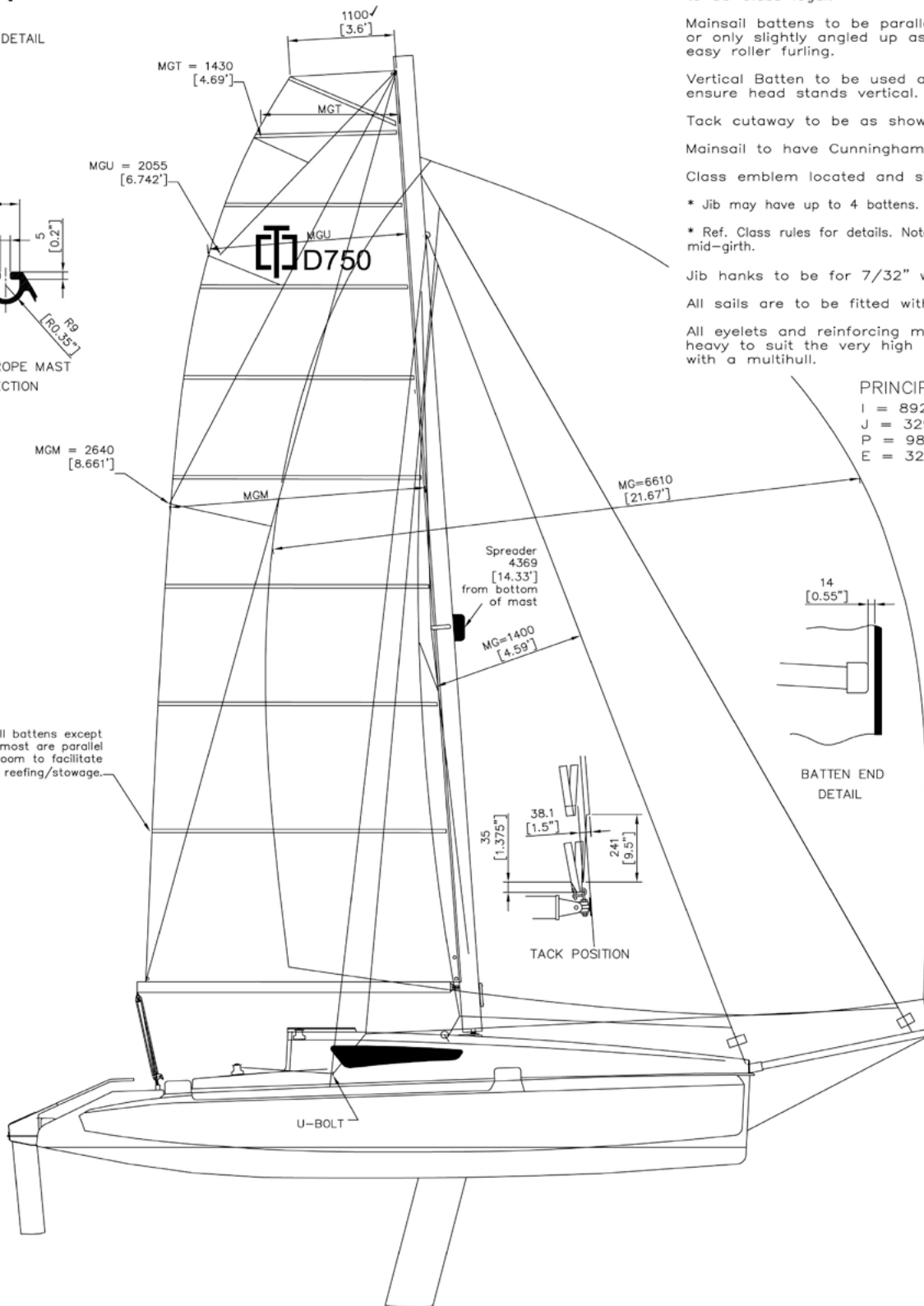

# C28 RS/C28 CR/C28 CE sail plan

## NOTES:

Square Top Mainsail as shown is required to be Class legal. Roach to be no more than 14" and 26" where shown, (14" and 28" with C28 RS).

Mainsail is designed to be almost flush with the top of the mast as shown -do not shorten luff, which has cutout as shown for halyard clearance.

Vertical Batten to be used at head to ensure head stands vertical.

Tack cutaway to be as shown

Mainsail has 2 sets of reefpoints, first set positioned as shown, second set optional.

Mainsail to have Cunningham eye fitted

Class emblem located and sized as shown.

Mainsail battens to be parallel with boom or only slightly angled up as shown for easy roller furling. Upper battens to have more angle as shown.

Jib to have four leach battens placed at equal distance on leach.

Jib hanks to be for 9/32" wire

All sails are to be fitted with telltales.

## Changes 3/15/97

C28 RS Mainsail:  
Leach 36.9 changed to 37'  
Luff 35.8' changed to 35' 9"  
4/20/97

Wear patch added to jib  
7/28/97 Rod insert added to boltrope at headboard  
4/9/98 Reef points redefined

Sail	Luff	Leach	Foot	Area	Remarks	Material
Mainsail	33.8'	35.1'	12.0'	300sq.ft	32" head 26" roach	Technora
Jib	30.1'	26.9'	12.4'	175sq.ft	LP 11'	Technora
Asymmetric Spinnaker	40.2'	35.8'	27.6'	780sq.ft		Nylon
Screacher	34'	28.7'	23.6'	358sq.ft	3/16" wire or 5/16" Kevlar Luff	Mylar
C28 RS Mainsail	35.8'	37'	12.1'	321sq.ft	32" head 28" roach	Technora

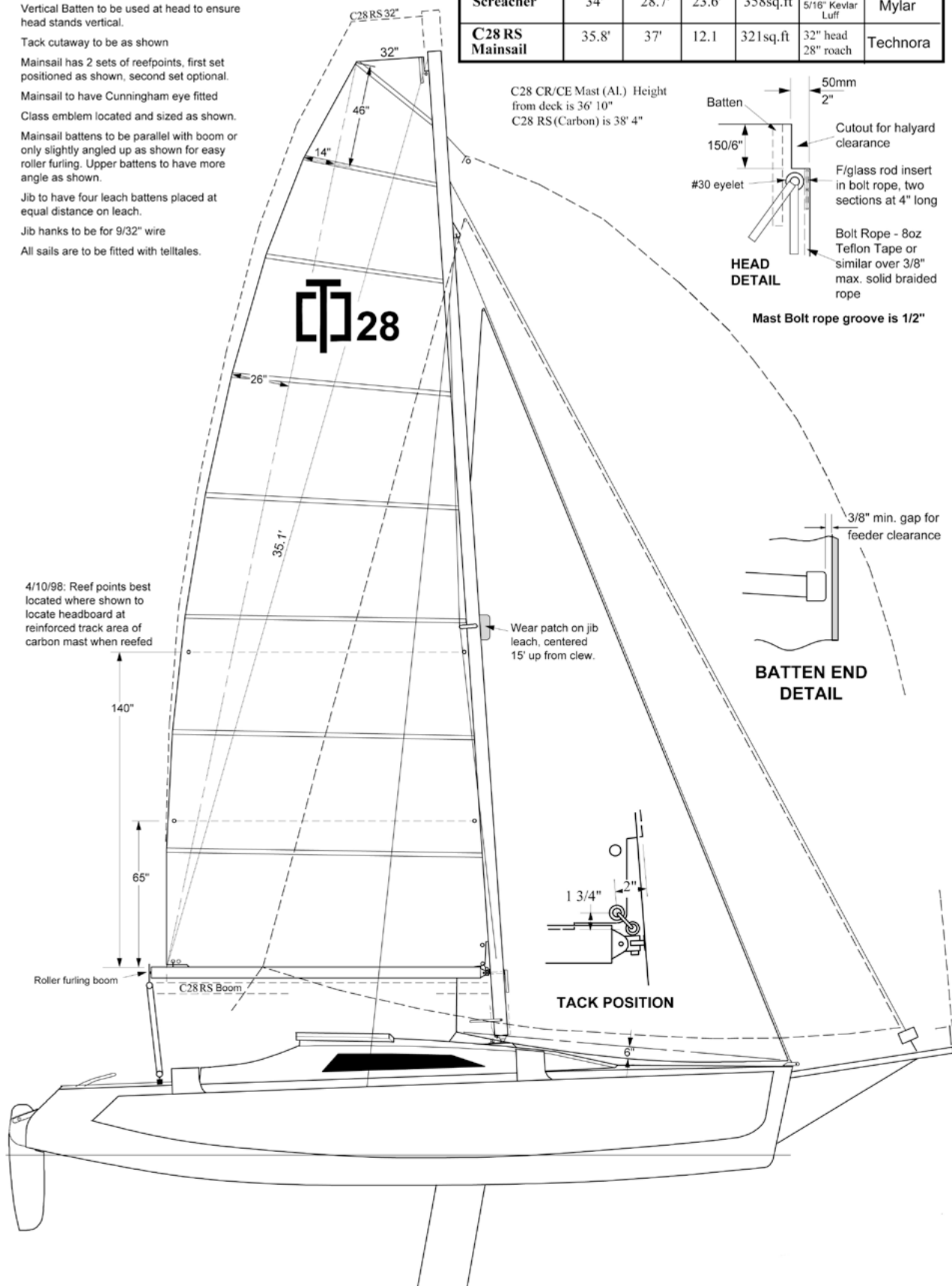

# C31RS/C31 CR/C31 UC sail plan

SAIL AREAS AND DIMENSIONS				
SAIL	LUFF	LEECH	FOOT	AREA
MAIN	12360 40.55'	12875 42.25'	4360 14.3'	39.7sq.m. 429 sq.ft.
JIB	10450 34.3'	9235 30.3'	4115 13.5'	20.2sq.m. 218 sq.ft.
SCREACHER	11890 39'	10610 34.8'	7865 25.8'	41.6sq.m. 449 sq.ft.
SPINN'R	13780 45.2'	12100 39.7'	9070 29.75'	92.2sq.m. 996 sq.ft.

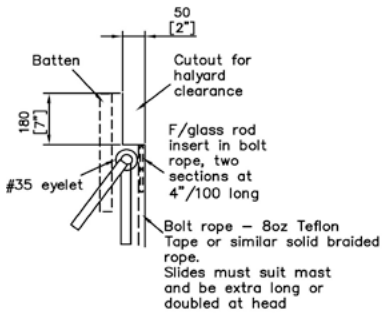

HEAD DETAIL

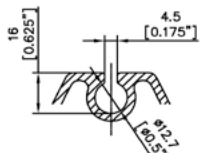

BOLT ROPE MAST SECTION

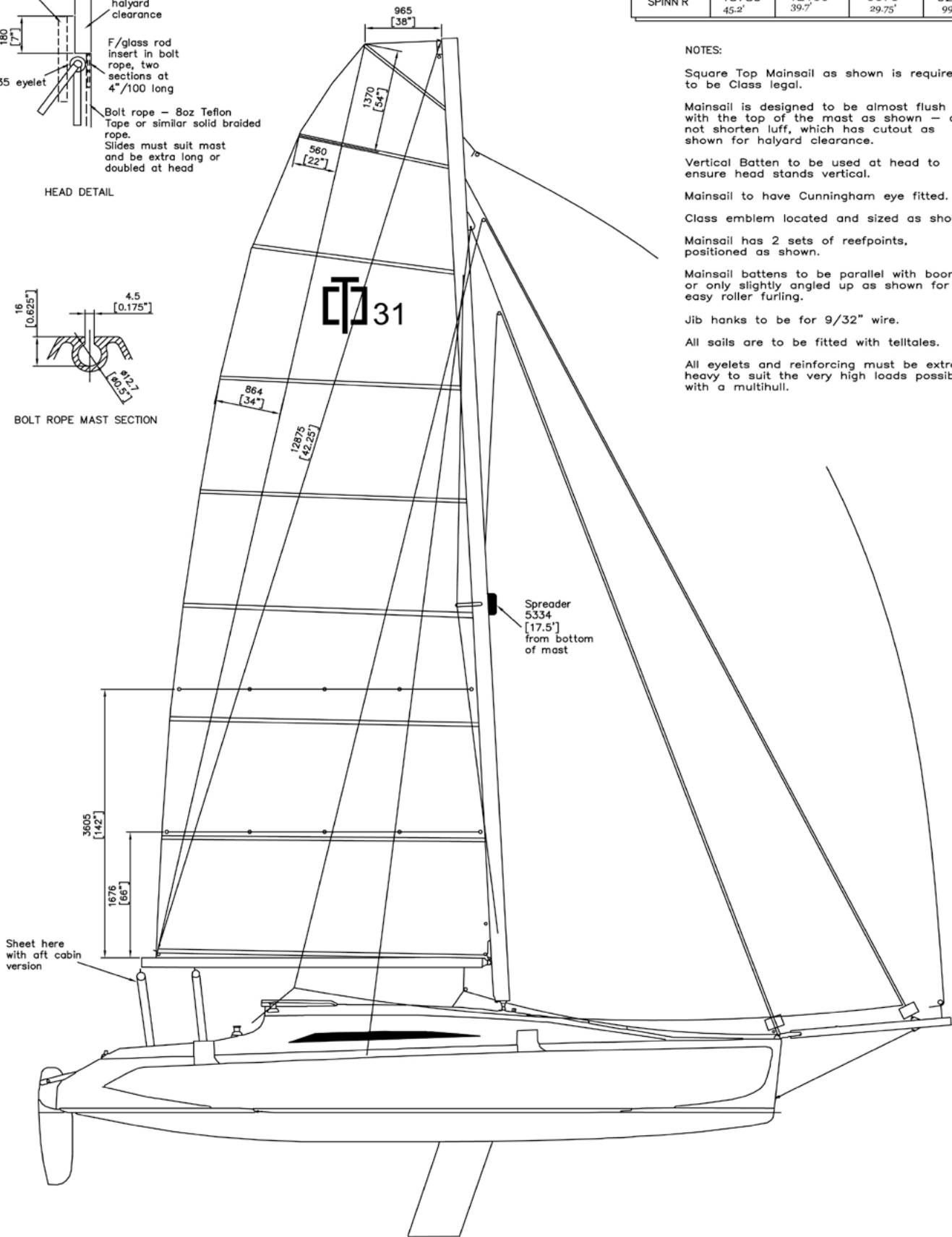

**NOTES:**

Square Top Mainsail as shown is required to be Class legal.

Mainsail is designed to be almost flush with the top of the mast as shown – do not shorten luff, which has cutout as shown for halyard clearance.

Vertical Batten to be used at head to ensure head stands vertical.

Mainsail to have Cunningham eye fitted.

Class emblem located and sized as shown.

Mainsail has 2 sets of reefpoints, positioned as shown.

Mainsail battens to be parallel with boom or only slightly angled up as shown for easy roller furling.

Jib hanks to be for 9/32" wire.

All sails are to be fitted with telltales.

All eyelets and reinforcing must be extra heavy to suit the very high loads possible with a multihull.



# Cruze 970 sail plan

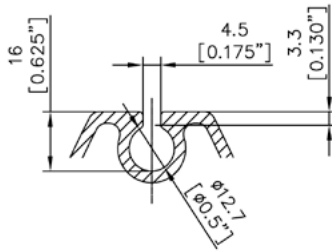

BOLT ROPE MAST SECTION

SAIL AREAS AND DIMENSIONS				
SAIL	LUFF	LEECH	FOOT	AREA
MAIN	11200 36.75'	11209 36.77'	4360 14.3'	38.8sq.m. 418 sq.ft.
JIB	10450 34.3'	9235 30.3'	4115 13.5'	20.2sq.m. 218 sq.ft.
SCREACHER	11890 39'	10610 34.8'	7865 25.8'	41.6sq.m. 449 sq.ft.
SPINN'R	13780 45.2'	12100 39.7'	9070 29.75'	92.2sq.m. 996 sq.ft.

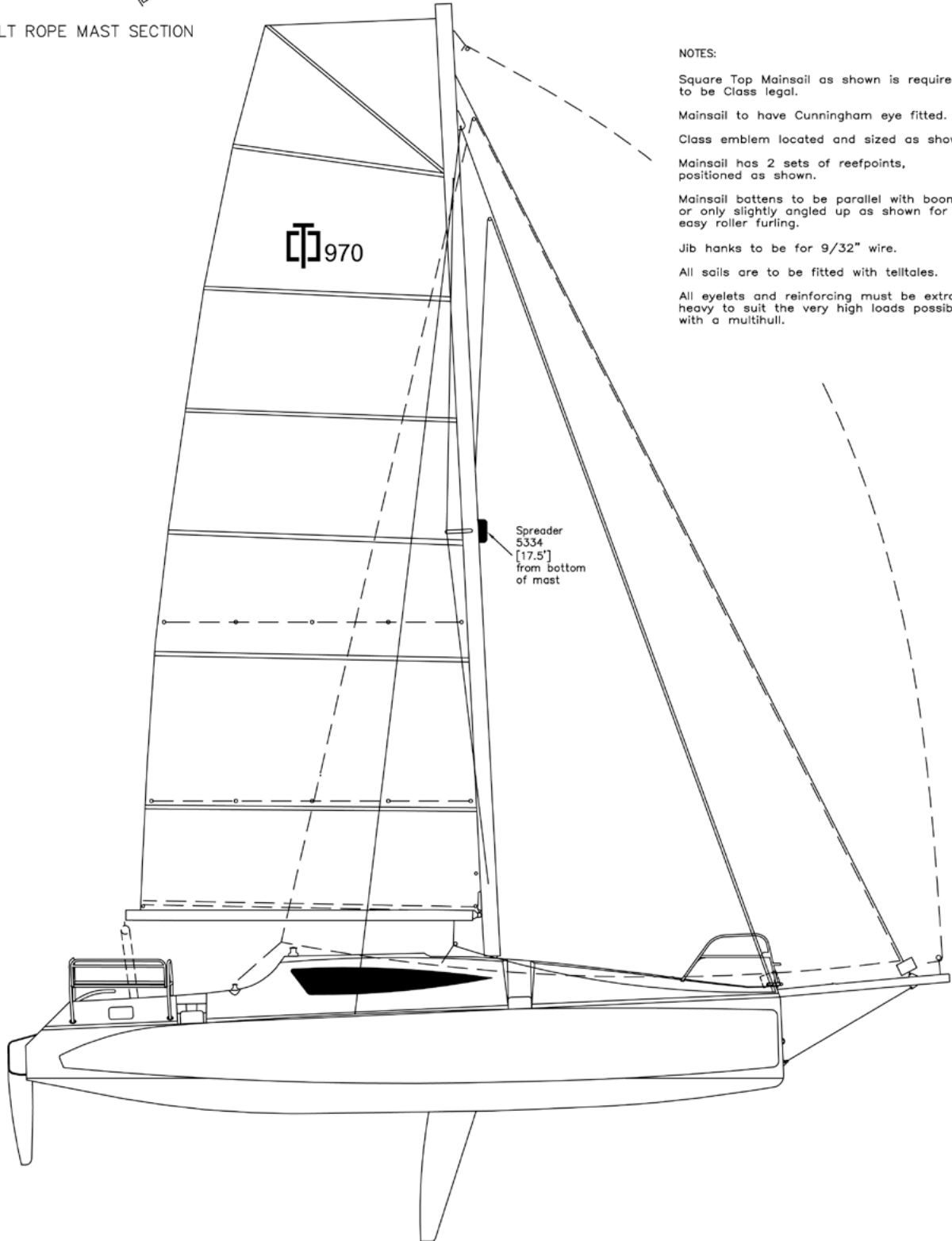

**NOTES:**

- Square Top Mainsail as shown is required to be Class legal.
- Mainsail to have Cunningham eye fitted.
- Class emblem located and sized as shown.
- Mainsail has 2 sets of reefpoints, positioned as shown.
- Mainsail battens to be parallel with boom or only slightly angled up as shown for easy roller furling.
- Jib hanks to be for 9/32" wire.
- All sails are to be fitted with telltales.
- All eyelets and reinforcing must be extra heavy to suit the very high loads possible with a multihull.

# C37 CR/RS sail plan

SAIL AREAS AND DIMENSIONS				
SAIL	LUFF	LEECH	FOOT	AREA
MAIN	14550 47.74'	15120 49.61'	4900 16.08'	58,26sq.m. 627.1 sq.ft.
JIB	12700 41.67'	11600 38.06'	4500 14.75'	27sq.m. 290.62 sq.ft.
SCREACHER	14050 45.92'	12200 40.02'	8790 28.84'	55sq.m. 592.03 sq.ft.
SPINNAKER	16022 52.56'	14850 48.72'	10300 33.79'	121sq.m. 1302.43 sq.ft.

**NOTES:**

1. Max. Righting Moment 122 200 N-m (90 000 ft./lb.)
2. Allow for 50mm (2") mast prebend.
3. Centroid of area, main and jib.
4. Square Top Mainsail as shown is required to be Class legal.

Mainsail is designed to be almost flush with the top of the mast as shown - do not shorten luff, which has cutout as shown for halyard clearance.

- 1/4 girth 3506
- 1/2 girth 4315
- 3/4 girth 4724

Mainsail has 7 battens top angled with a head width of 1800mm

Vertical Batten to be used at head to ensure head stands vertical.

Mainsail batten pocket ends to suit harken batten cars #3834 x 7 (10mm Stud)

Mainsail head board to suit harken head board car assembly #3833 x 1

Mainsail intermediate straps to suit harken cars #3836 x 2

Mainsail has 2 sets of reefpoints, positioned as shown

Mainsail to have Cunningham eye fitted.

Class emblem located and sized as shown.

Jib has straight leech with vertical leech battens to allow furling.

Jib made to suit harken cruising unit 1.

Jib 1/2 girth 2095

Screacher has a 50.3% mid girth.

Spinnaker has a 92% mid girth.

All sails are to be fitted with telltales.

All eyelets and reinforcing must be extra heavy to suit the very high loads possible with a multihull.

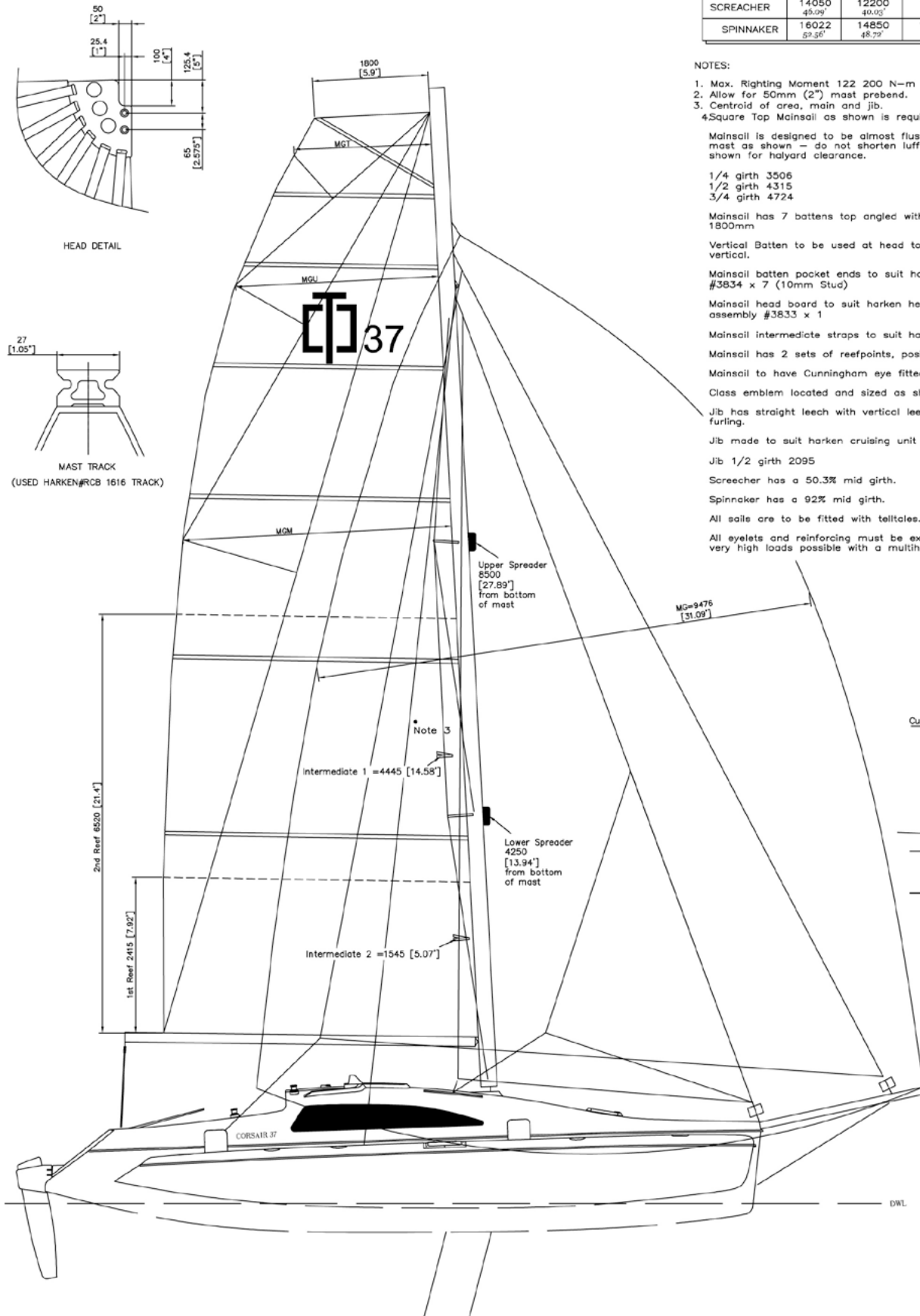

# CORSAIR ACCOMODATION PLANS

## C24 MKII

accommodation plan

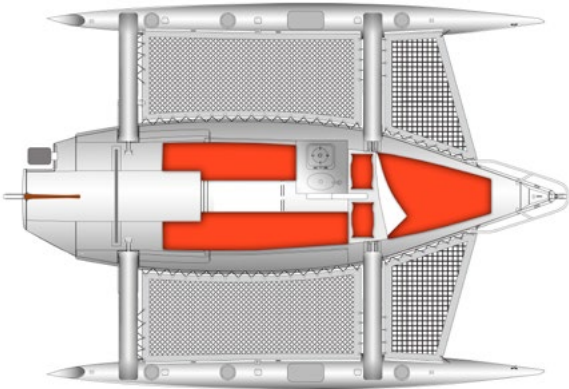

## Sprint 750 MKII

accommodation plan

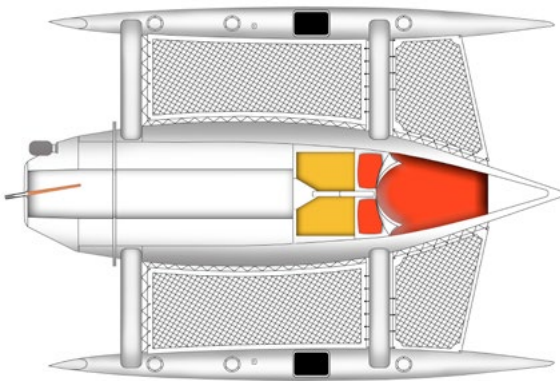

## Dash 750 MKII

accommodation plan

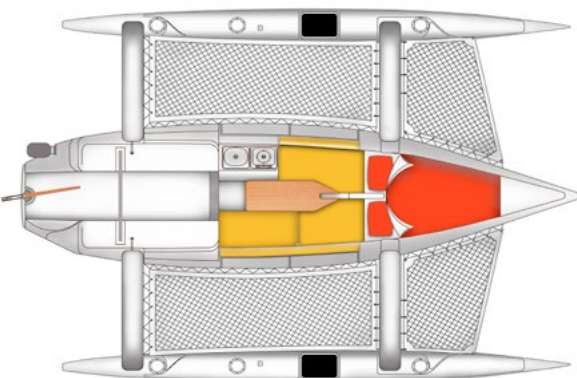

## C28 RS

accommodation plan

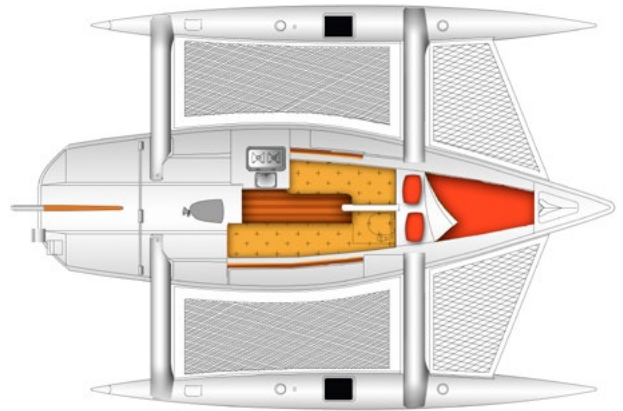

## C28 CR

accommodation plan

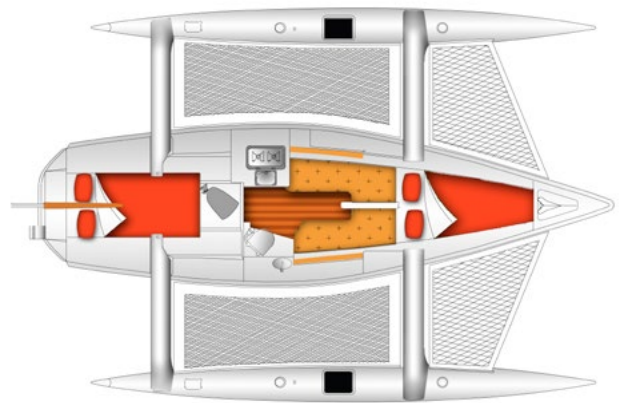

## C28 CE

accommodation plan

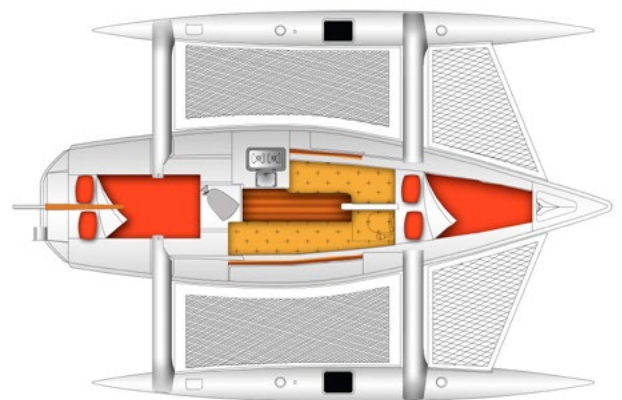

**C31 RS**

accommodation plan

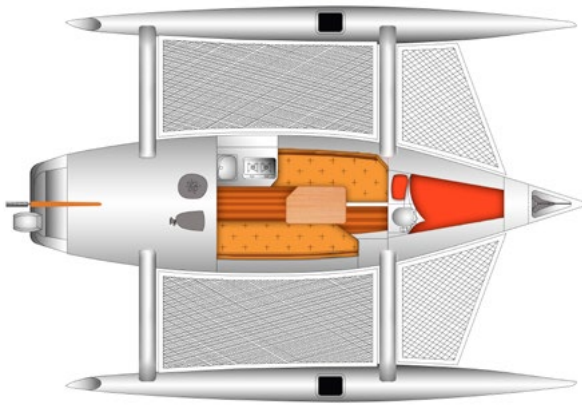

**C31 CR**

accommodation plan

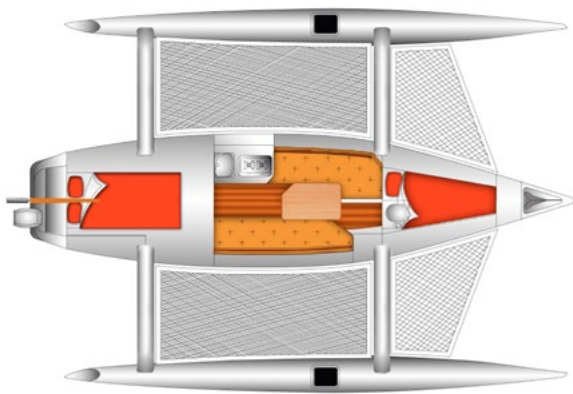

**C31 UC**

accommodation plan

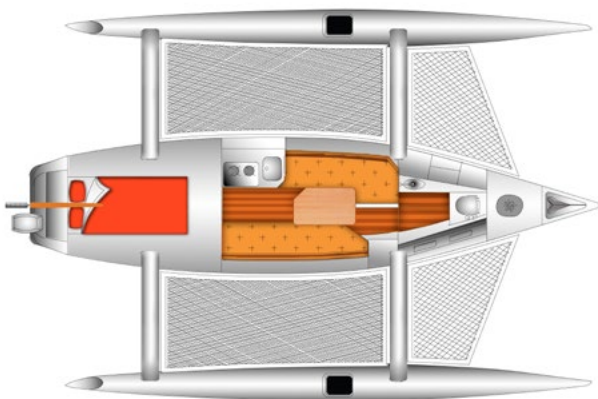

**Cruze 970**

accommodation plan

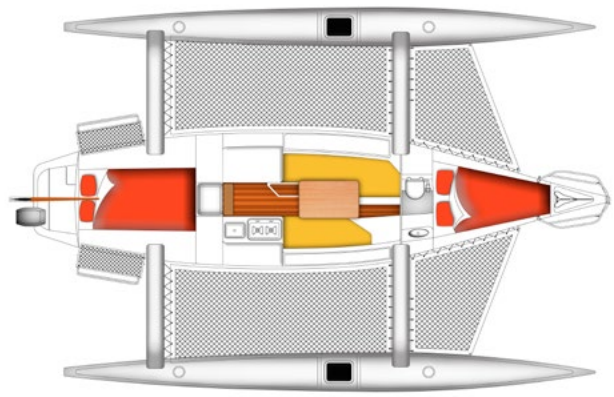

**C37 CR/RS**

accommodation plan

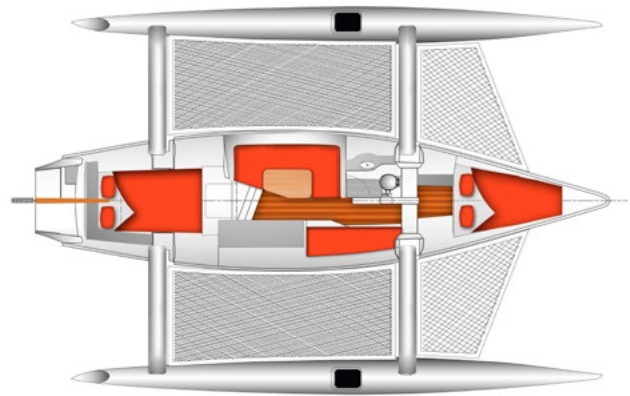

# CORSAIR DECK LAYOUTS

## Deck layout C24 MKII (part1)

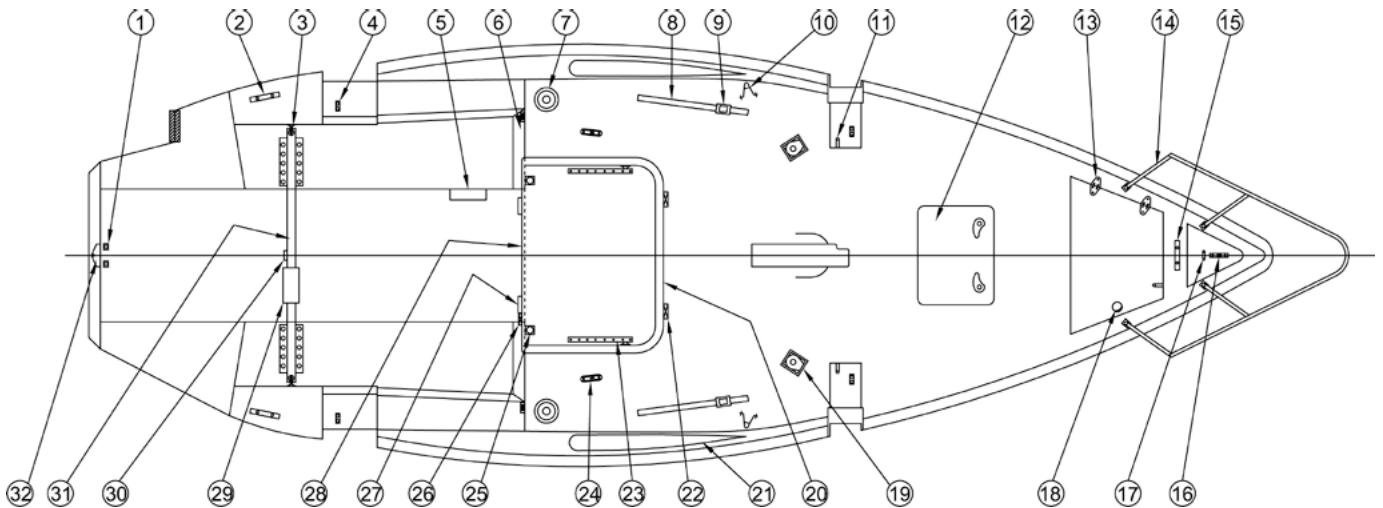

- |                                       |                                       |                                    |
|---------------------------------------|---------------------------------------|------------------------------------|
| 1. Pipe PVC 1"                        | Backing plate U-bolt                  | Plate backup camcleat              |
| Collar aft mast support               | 12. Hatch 30 low                      | 25. Bracket deck plastic white     |
| Cap PVC 1" aft mast tube              | 13. Hinge anchor locker               | Insert poptop                      |
| 2. Cleat 6"                           | 14. Pulpit                            | Bushing poptop addition            |
| 3. Block w/shackle Harken             | 15. Cleat 8" chrome                   | Bushing poptop                     |
| Eye strap Harken                      | Plate backup cleat mooring            | S/S tube                           |
| Spring traveler outhaul block         | 16. Chain plate forestay              | Bracket poptop                     |
| 4. Pad beam bolt                      | 17. Bolt                              | Pin S/S quick                      |
| Spacer beam bolt pad                  | Backing plate U-bolt                  | Chain S/S                          |
| 5. Winch handle pocket Seadog         | 18. Latch flush pull black            | Chain end with eye                 |
| 6. Camcleat Ronstan                   | 19. Block cheek 2.25                  | Sleeve brass retainer              |
| Plate backup camcleat                 | Packing block for cheek block         | 26. Nut 1/4" barrel Beckson chrome |
| Wedge camcleat large                  | Plate back up for check block         | Nut #10 barrel Beckson chrome      |
| 7. Winch B16.2A                       | 20. Trimloc 3/16" poptop black s/seal | 27. Hasp Perko                     |
| Plate backup winch                    | 21. Window side                       | Packing block lock UHMW poly       |
| 8. Low beam w/pinstop hole            | 22. Hasp Perko                        | 28. Plastic 1/8" black hatch slide |
| Plate backup t-track schaffer         | 23. Hinge deck side mount             | Hatch main companionway lower      |
| End stop trim cap                     | S/S tube                              | Hatch main companionway top        |
| 9. Jib lead slider                    | Insert poptop                         | 29. Plate main hatch foot UHMW     |
| Block 57mm Carbo Ti-lite              | Bracket deck plastic white            | 30. Traveler car Harken H1628      |
| 10. Mast raising wire anchor loop     | Track slide                           | 31. Gudgeon aft mast support       |
| Plate backup raising loops            | Track S/S poptop                      | 32. Traveler track anodized        |
| Eye strap w/ferrule                   | Track end                             | Sub. traveler welded 3 hole plate  |
| Bushing nylon 1/4" mast raising brkts | Track stop                            | End stop for high beam traveler    |
| 11. U-bolt                            | Nut #10 barrel Beckson chrome         | Gudgeon rudder transom             |
|                                       | 24. Camcleat plastic                  |                                    |

## Deck layout C24 MKII (part2)

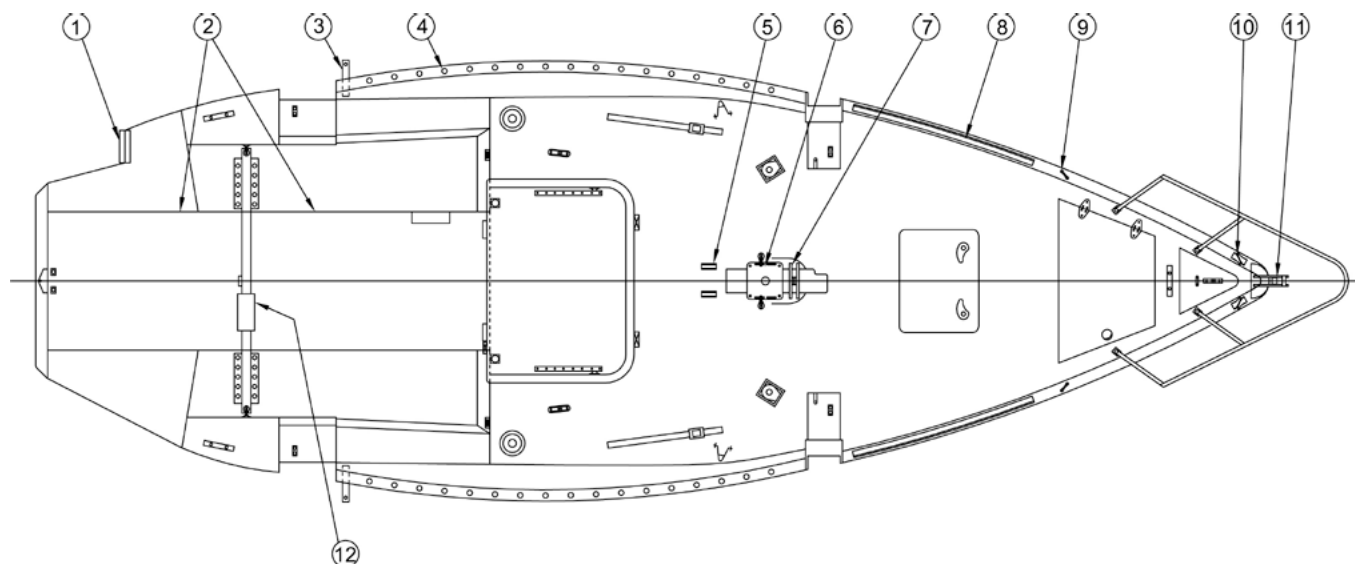

- |                                  |                                  |                         |
|----------------------------------|----------------------------------|-------------------------|
| 1. Pad engine mount (outboard)   | Chain ends with eye              | Pin sheave box          |
| Pad engine mount (inboard)       | Split rings                      | Sheave D/B control line |
| 2. Trim edging 1/4" white pebble | 4. Wing net rope retaining white | 8. Toe rail bow         |
| 3. Bracket 24 beam retaining     | 5. Hinge deck 90°                | 9. Eye strap RF1055     |
| Bracket 24 hull beam retaining   | Pin detent 1/4" x 1-1/2"         | 6. 10. Bow chock 4-1/2" |
| Pin rigging                      | Mast step                        | 11. Bow roller mount    |
| Chain (pin retaining)            | 7. Side sheave box               | Sheave bow roller       |

## Float layout C24 MKII

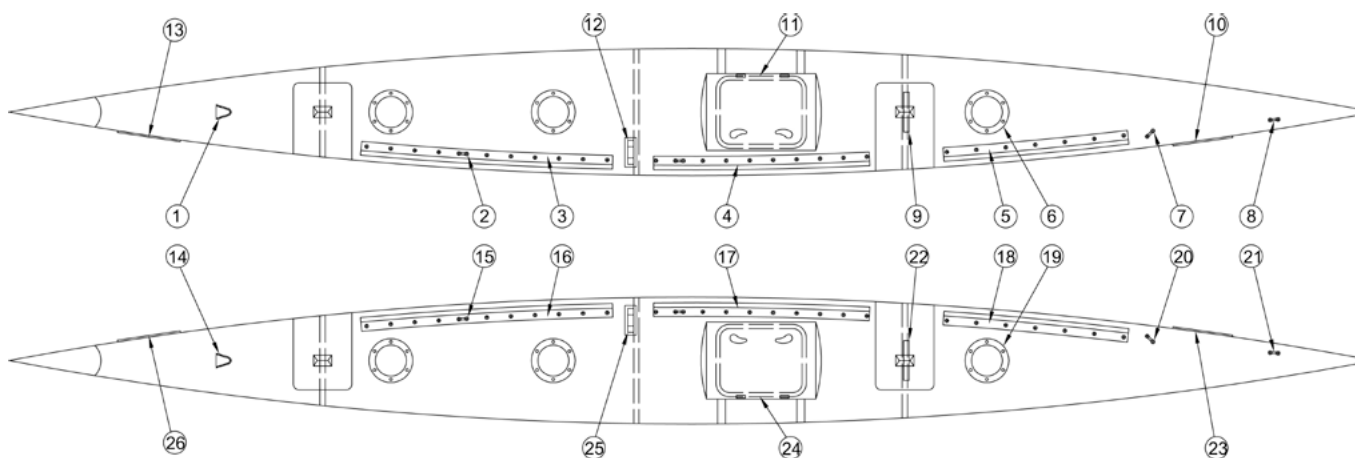

- |                                 |                                  |                          |
|---------------------------------|----------------------------------|--------------------------|
| 1. Vent midget                  | 11. Hatch 30 low profile         | 20. Eye saddle RF134     |
| 2. Eye strap RF1055             | 12. Chain plate                  | 21. Eye strap RF528      |
| 3. Rail 24 wing net 65" aft     | Cover chain plate                | 22. Hatch 4"             |
| 4. Rail 24 wing net 54" fwd     | 13. Non-skid strip               | 23. Non-skid strip       |
| 5. Rail 24 bow net 38"          | 14. Vent midget                  | 24. Hatch 30 low profile |
| 6. Hatch 6" Viking/ Becson 1139 | 15. Eye strap RF1055             | 25. Chain plate          |
| 7. Eye saddle RF134             | 16. Rail 24 wing net 65" aft     | Cover chain plate        |
| 8. Eye strap RF528              | 17. Rail 24 wing net 54" fwd     | 26. Non-skid strip       |
| 9. Hatch 4"                     | 18. Rail 24 Bow net 38"          |                          |
| 10. Non-skid strip              | 19. Hatch 6" Viking/ Becson 1139 |                          |

## Deck layout Sprint 750 MKII

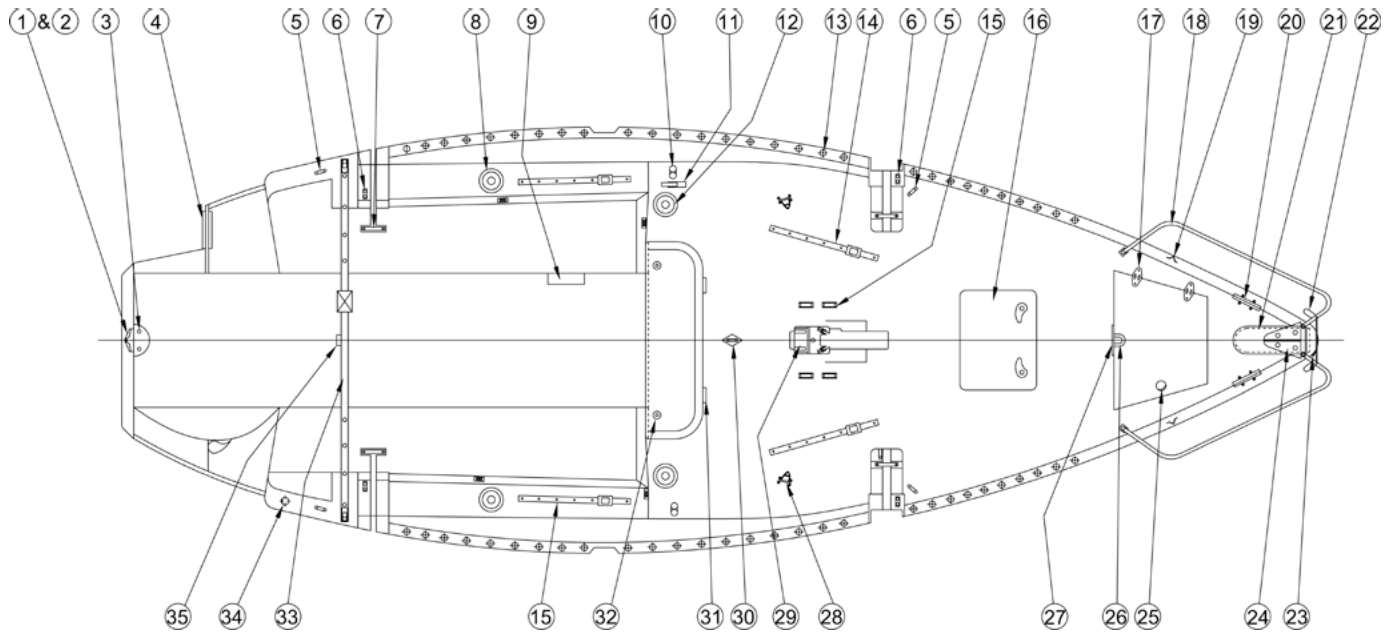

- |                                   |                                      |   |
|-----------------------------------|--------------------------------------|---|
| 1. Gudgeon lower plate            | Jib lead slider                      | 29. Mast raising 750 hinge clip         |
| 2. Gudgeon upper plate            | Block 57mm Carbo Ti-lite             | Mast base plate                         |
| 3. Pipe PVC 1"                    | 15. Block stand up                   | Sheave 36 lazy cradle                   |
| Cap PVC 1" aft mast support tube  | 16. Hatch 30 low Lewmar              | Mast step pivot ball                    |
| 4. Pad engine mount (outboard)    | 17. Hinge anchor locker              | Camcleat RF5000                         |
| 5. U bolt                         | 18. Pulpit                           | Fairlead for small camcleat             |
| 6. Pad beam bolt                  | 19. Eye strap RF528                  | 30. U-bolt RF529 w/base pad             |
| Spacer beam bolt pad              | 20. Cleat 8" chrome                  | or rotation prevent                     |
| 7. Pin pivot upper folding strut  | 21. Cover 750 spin pole sleeve       | 31. Hinge Pr companionway smoked        |
| 8. Winch 2 SPD 20.2 Harken        | 22. Light navigation                 | Spacer hatch hinge                      |
| Plate backup winch                | 23. Hook spring clip w/base for mast | 32. Sealing cover small used w/ Southco |
| 9. Winch handle pocket Seadog     | Raising line off trailer             | lock                                    |
| 10. Camcleat Harken carbon        | 24. Fitting forestay                 | Tubular key used w/Southco lock         |
| Plate backup camcleat             | 25. Latch flush pull black           | Lock waterproof tubular head            |
| 11. Rope clutch single spinlock   | 26. U bolt                           | Striker plate                           |
| Plate backup Spinlock clutch      | 27. Hatch 4"                         | 33. Block cheek                         |
| 12. Winch 1 SPD 20. STA Harken    | 28. Mast raising wire anchor loop    | Bump rudder track stop 750 main         |
| Plate backup winch                | Plate backup raising loops           | End cap traveler track                  |
| 13. Wing net rope retaining white | Eye strap s/ferrule                  | Traveler track 75" midrange Hi          |
| 14. Low beam w/pinstop hole       | Bushing nylon 1/4" mast raising      | beam anodized                           |
| Plate backup t-track Harken       | brkts                                | Traveler car Harken H1628               |
| End stop trim cap                 | Cotter ring                          | 34. Stern light                         |
|                                   |                                      | 35. Gudgeon aft mast support            |

## Float layout Sprint 750 MKII

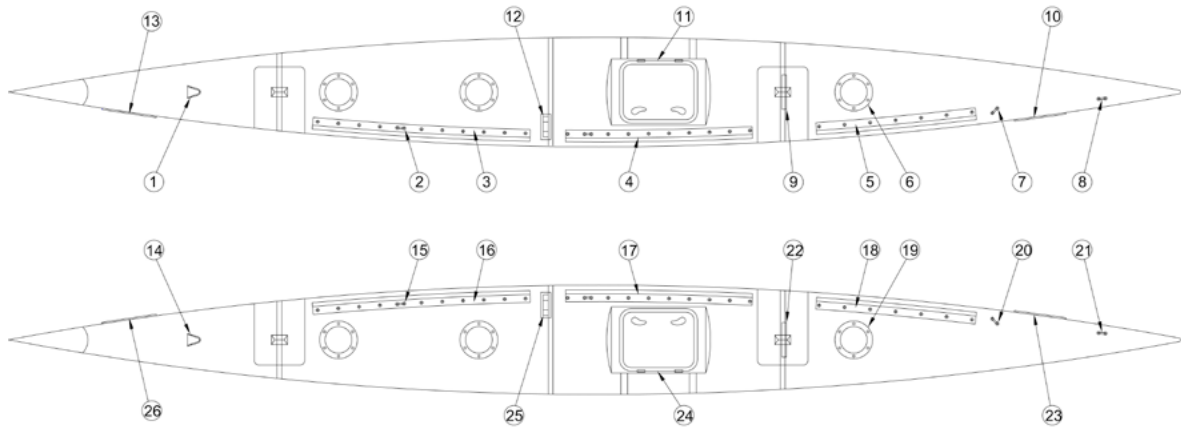

- |                                 |                                  |                          |
|---------------------------------|----------------------------------|--------------------------|
| 1. Vent midget                  | 11. Hatch 30 low profile         | 20. Eye saddle RF134     |
| 2. Eye strap RF1055             | 12. Chain plate                  | 21. Eye strap RF528      |
| 3. Rail 24 wing net 65" aft     | Cover chain plate                | 22. Hatch 4"             |
| 4. Rail 24 wing net 54" fwd     | 13. Non-skid                     | 23. Non-skid             |
| 5. Rail 24 bow net 38"          | 14. Vent midget                  | 24. Hatch 30 low profile |
| 6. Hatch 6" Viking/ Becson 1139 | 15. Eye strap RF1055             | 25. Chain plate          |
| 7. Eye saddle RF134             | 16. Rail 24 wing net 65" aft     | Cover chain plate        |
| 8. Eye strap RF528              | 17. Rail 24 wing net 54" fwd     | 26. Non-skid strip       |
| 9. Hatch 4"                     | 18. Rail 24 Bow net 38"          |                          |
| 10. Non-skid strip              | 19. Hatch 6" Viking/ Becson 1139 |                          |

## Deck layout Dash 750 MKII

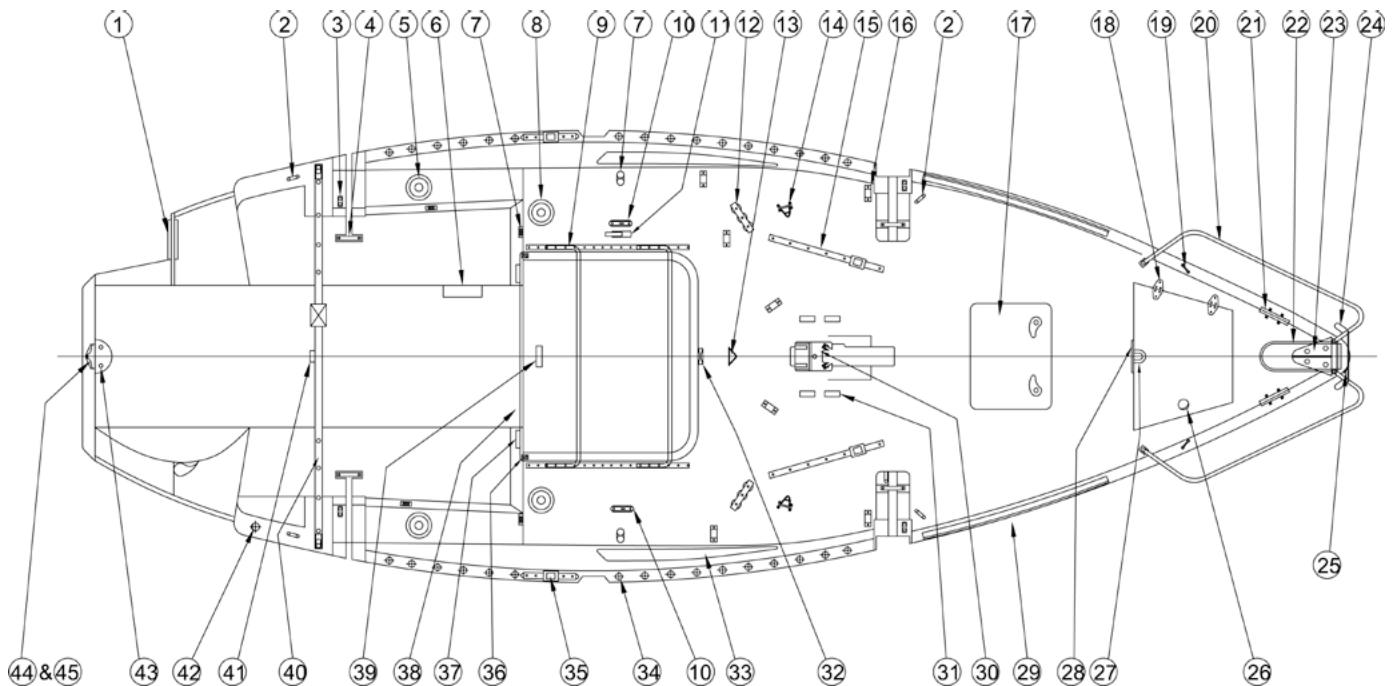

- |                                  |                               |                                   |
|----------------------------------|-------------------------------|-----------------------------------|
| 1. Pad engine mount (outboard)   | Backing plate winch           | Backing plate camcleat            |
| Pad engine mount (inboard)       | 6. Winch handle pocket Seadog | 11. Rope clutch single Spinlock   |
| 2. U-bolt                        | 7. Camcleat Harken carbon     | Backing plate Spinlock            |
| Backing plate U-bolt             | Backing plate camcleat        | 12. Deck organizer 3 block        |
| 3. Pad beam bolt                 | 8. Winch B16.2A self tailing  | 13. Pad eye folding for rotation  |
| Spacer beam bolt pad             | Backing plate winch           | preventing                        |
| 4. Pin pivot upper folding strut | 9. Poptop                     | Backing plate pad eye folding     |
| 5. Winch B16.2A                  | 10. Camcleat plastic          | 14. Mast raising wire anchor loop |



- |  |                                      |  |
|--|--------------------------------------|--|
| Backing plate raising loops              | 24. Light navigation                 | Spacer cabin wing net rail                       |
| Eye strap w/ferrule rig                  | 25. Hook spring clip w/base for mast | 36. Poptop back lock plate                       |
| Bushing nylon 1/4" mast raising brackets | 26. Latch flush pull black           | 37. Sealing cover small Tubular key              |
| Cotter ring                              | 27. U-bolt                           | Lock waterproof tubular head                     |
| 15. Low beam w/ pinstop hole             | 28. Hatch 4"                         | 38. Companionway step                            |
| Plate backup t-track Harken              | 29. Toe rail bow                     | 39. Poptop handle                                |
| End stop trim cap                        | 30. Mast raising 750 hinge clip      | 40. Block cheek                                  |
| Jib lead slider                          | Mast base plate                      | Bump rudder track stop 750 main                  |
| Block 57mm Carbo Ti-lite                 | Sheave 36 lazy cradle                | End cap traveler track                           |
| Backing plate SS track Harken track      | Mast step pivot ball                 | Traveler track 75" mid range Hi beam anodized    |
| 16. Fairlead nylon                       | 31. Block stand up                   | Traveler car Harken H1628                        |
| Plate backup fairlead                    | 32. Poptop latching plate            |  |
| 17. Hatch 30 low                         | Poptop front lock plate              | 41. Gudgeon aft mast support                     |
| 18. Hinge anchor locker                  | 33. Window main side                 | 42. Stern light                                  |
| 19. Eye strap RF1055                     | 34. Wing net rope retaining white    | 43. Pipe PVC 1" Cap PVC 1" aft mast support tube |
| 20. Pulpit                               | 35. Low beam w/pin stop hole         | 44. Gudgeon lower plate                          |
| 21. Cleat 8" chrome                      | End stop trim cap                    | 45. Gudgeon upper plate                          |
| 22. Cover 750 spin pole sleeve           | Jib lead slider                      |  |
| 23. Fitting forestay                     | Block 57mm Carbo Ti-lite             |  |

### Float layout Dash 750 MKII

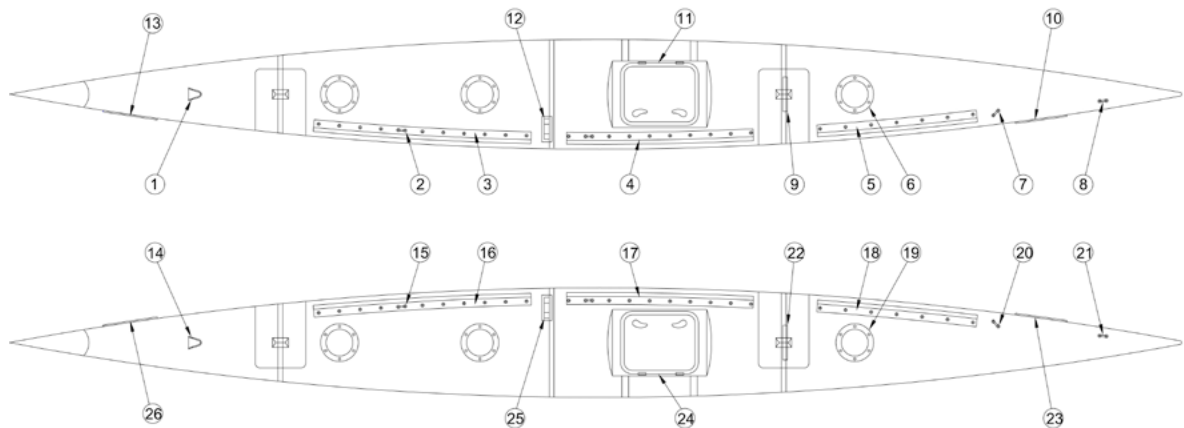

- |                                 |                                  |                          |
|---------------------------------|----------------------------------|--------------------------|
| 1. Vent midget                  | 11. Hatch 30 low profile         | 20. Eye saddle RF134     |
| 2. Eye strap RF1055             | 12. Chain plate                  | 21. Eye strap RF528      |
| 3. Rail 24 wing net 65" aft     | Cover chain plate                | 22. Hatch 4"             |
| 4. Rail 24 wing net 54" fwd     | 13. Non-skid                     | 23. Non-skid             |
| 5. Rail 24 bow net 38"          | 14. Vent midget                  | 24. Hatch 30 low profile |
| 6. Hatch 6" Viking/ Becson 1139 | 15. Eye strap RF1055             | 25. Chain plate          |
| 7. Eye saddle RF134             | 16. Rail 24 wing net 65" aft     | Cover chain plate        |
| 8. Eye strap RF528              | 17. Rail 24 wing net 54" fwd     | 26. Non-skid             |
| 9. Hatch 4"                     | 18. Rail 24 Bow net 38"          |                          |
| 10. Non-skid                    | 19. Hatch 6" Viking/ Becson 1139 |                          |

## Deck layout C28 RS (part1)

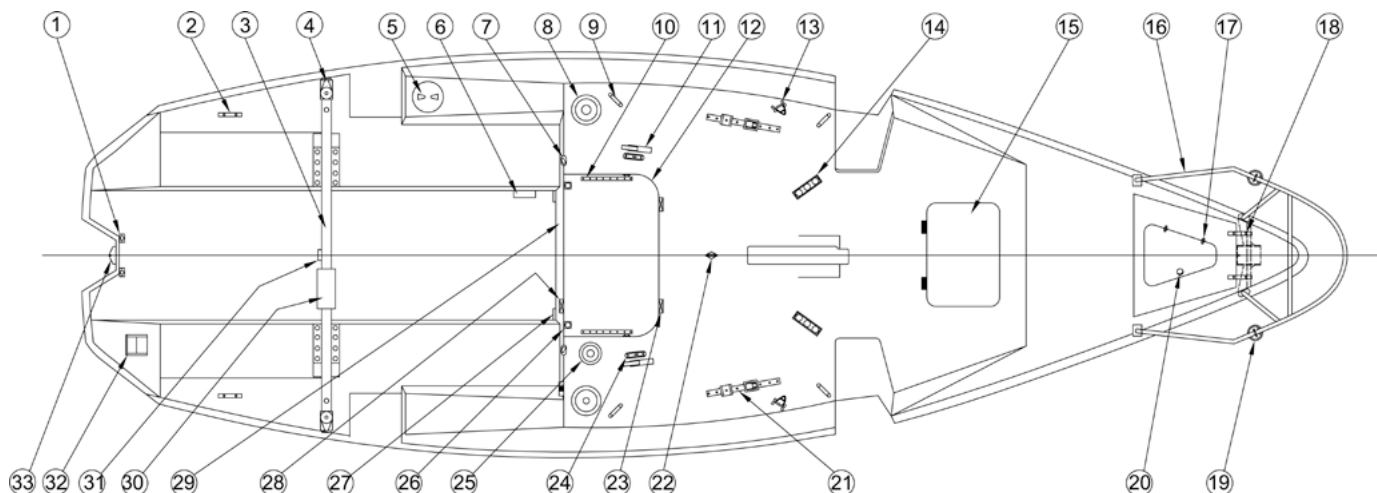

- |  |   |   |
|--|---|---|
| 1. Collar aft mast support<br>Pipe PVC 1-1/4" aft mast<br>Cap PVC aft mast support tubes   | Nut #10 barrel Beckson chrome   | 24. Camcleat plastic<br>Plate backup camcleat   |
| 2. Cleat 8 chrome<br>Plate backup cleat mooring  | 11. Rope clutch single spinlock<br>Plate backup rope clutch   | 25. Winch B32.2 STD self tailing<br>Plate backup winch  |
| 3. Traveler track<br>Sub traveler track & bar welded<br>Cap end traveler<br>Wing net rope retainer white   | 12. Trimloc 3/16" poptop black w/seal   | 26. Bracket deck plastic white<br>Insert poptop<br>Bushing poptop<br>S/S tube<br>Bracket poptop<br>Pin S/S quick 3/16"x1-1/2" |
| 4. Control traveler  | 13. Eye strap w/ ferrule<br>Plate backup raising loop<br>Bushing nylon mast raising<br>Mast raising wire<br>Cotter ring | 27. Plastic actl. 1/8" black hatch slide<br>Hatch main companionway lower<br>Hatch main companionway top                      |
| 5. Hatch 6" white  | 14. Organizer deck triple Harken<br>Pad backup deck organizer<br>Plate backup triple organizer                          | 28. Hasp Perko<br>Packing block lock UHHMS poly   |
| 6. Winch handle pocket Seadog  | 15. Hatch 44 fwd w/stay arm<br>Hatch trim 44 white  | 29. Plate main hatch foot   |
| 7. Camcleat plastic<br>Plate backup camcleat   | 16. Pulpit  | 30. Traveler car  |
| 8. Winch B40.2A two speed<br>Plate backup winch  | 17. Hinge anchor locker S/S   | 31. Gudgeon aft mast support  |
| 9. Lifting eye (U-bolt)<br>Plate backup lifting eye  | 18. Cleat 8 chrome<br>Plate backup cleat mooring  | 32. Bracket outboard  |
| 10. Hinge deck side mount<br>S/S tube<br>Insert poptop<br>Bracket deck plastic white<br>Track slide<br>Track S/S poptop<br>Tracks end<br>Tracks stop | 19. Light navigation port and stb   | 33. Gudgeon transom   |
|  | 20. Latch flush pull black  |   |
|  | 21. T-track alum. 25mm<br>Plate sheet track<br>Stop end t-track Harken<br>Car genoa lead alum.<br>Stop t-track Harken   |   |
|  | 22. U-bolt w/base pad   |   |
|  | 23. Hasp Perko  |   |

## Deck layout C28 RS (part2)

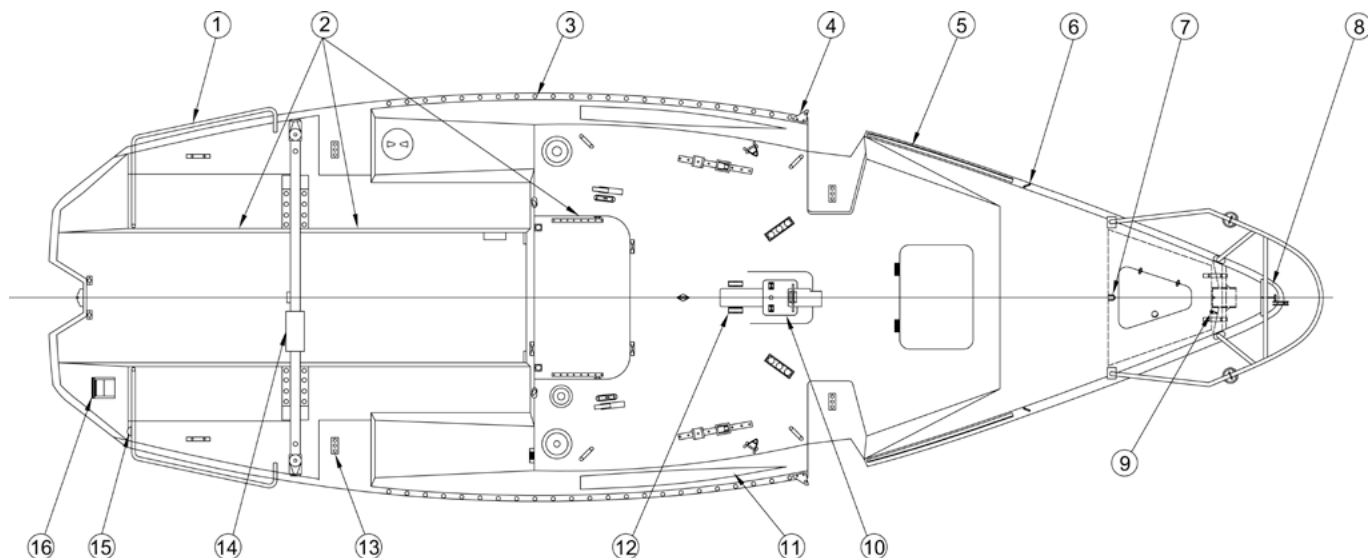

- |   |   |   |
|---|---|---|
| 1. Pushpit  | Rod polyurethane cast   | 11. Window side large                           |
| 2. Trim edging 1/4" white pebble  | 5. Bow toe rail   | 12. Hinge deck 90°<br>Pin detent 1/4"           |
| 3. Wing net rope retainer white   | 6. Eye strap Rf134  | 13. Bracket folding upper strut<br>Pad bolt S/S |
| 4. Beam retaining plate cabin<br>Chain (pin retaining)<br>Chain ends with eye<br>Split rings<br>Pin rigging<br>Beam retaining bracket | 7. U-bolt (inside anchor well)<br>Bow roller<br>Sheave bow roller | 14. Rope 8mm blue                               |
|   | 8. Block stand-up<br>Rope 6mm black                               | 15. Light LED stern                             |
|   | 10. Mast base   | 16. Pads outboard bracket                       |

## Float layout C28 RS

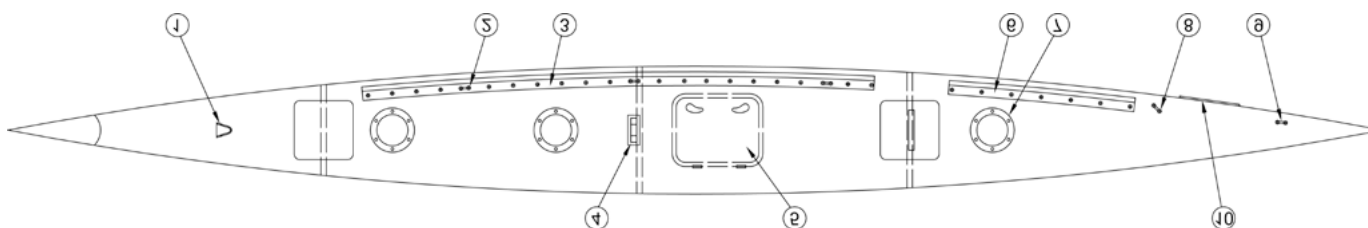

- |                     |                           |                     |
|---------------------|---------------------------|---------------------|
| 1. Vent midget      | Cover chain plate         | 8. Eye saddle RF134 |
| 2. Eye strap        | 5. Hatch 30 low profile   | 9. Eye strap RF528  |
| 3. Rail 28 wing net | 6. Rail 24 bow net 38"    | 10. Non-skid        |
| 4. Chain plate      | 7. Hatch 6" Viking/Becson |                     |

## Deck layout C28 CR (part1)

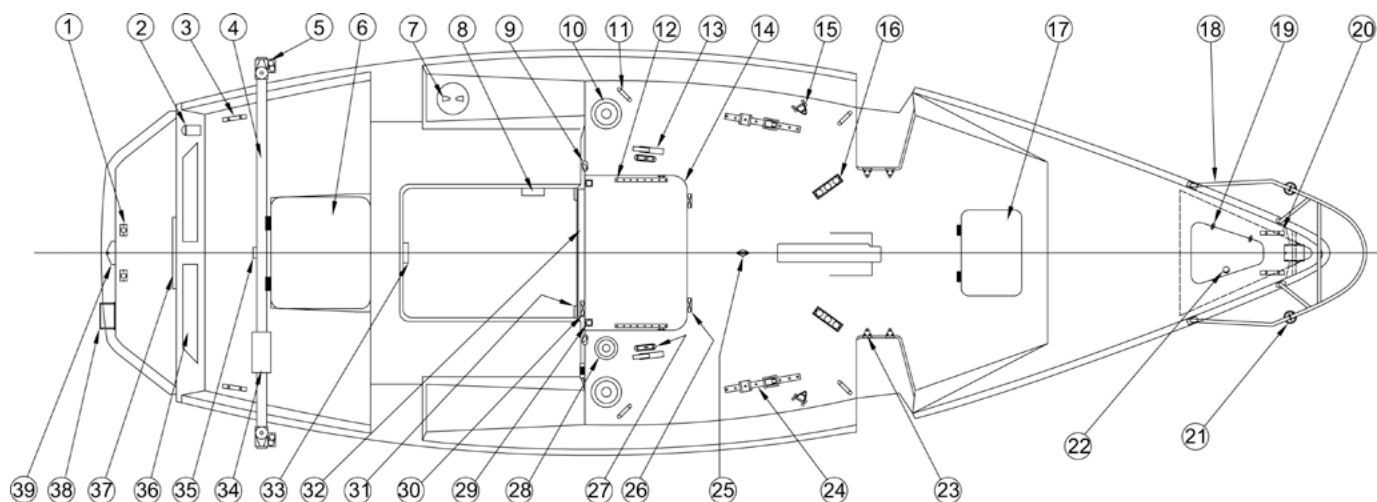

- |                                       |                                       |  |
|---------------------------------------|---------------------------------------|--|
| 1. Collar aft mast support            | Track stop                            | Plate backup winch                       |
| Pipe PVC 1-1/4" aft mast              | Nut #10 barrel Beckson chrome         | 28. Winch B32.2 STD self tailing         |
| Cap PVC aft mast support tubes        | 13. Rope clutch single Spinlock       | Plate backup winch                       |
| 2. Light LED stern                    | Plate backup rope clutch              | 29. Bracket deck plastic white           |
| Bracket stern light                   | 14. Trimloc 3/16" poptop black w/seal | Insert poptop                            |
| 3. Cleat 8 chrome                     | 15. Eye strap w/ferrule               | Bushing poptop addition                  |
| Plate backup cleat mooring            | Plate backup raising loop             | Bushing poptop                           |
| 4. Traveler track                     | Bushing nylon mast raising brackets   | S/S tube                                 |
| Sub. drill and anodize traveler track | Cotter ring                           | Bracket poptop                           |
| Traveler horse end bracket            | Mast raising wire anchor loop         | Pin S/S quick 3/16" x 1-1/2"             |
| Cap end traveler                      | 16. Organize deck triple Harken       | Chain S/S                                |
| 5. Control traveler Pr                | Pad backup deck organizer             | Chain end with eye                       |
| 6. Hatch 60 low profile               | Plate backup triple organizer         | Sleeve brass retainer (for bead chain)   |
| Hatch trim 60 white                   | 17. Hatch 44 fwd w/stay arm           | Nut 1/4" barrel Beckson chrome           |
| 7. Hatch 6" white                     | Hatch trim 44 white                   | Nut #10 barrel Beckson chrome            |
| 8. Winch handle pocket Seadog         | 18. Pulpit                            | 30. Plastic actl. 1/8" black hatch slide |
| 9. Camcleat plastic                   | 19. Hinge anchor locker S/S           | Hatch main companionway lower            |
| Plate backup camcleat                 | 20. Cleat 8 chrome                    | Hatch main companionway top              |
| 10. Winch B40.2A two speed            | 21. Plate backup cleat mooring light  | 31. Hasp Perko                           |
| Plate backup winch                    | navigation port and stb               | Packing block lock UHMW poly             |
| 11. Lifting eye (U-bolt)              | 22. Latch flush pull black            | 32. Plate main hatch foot                |
| Plate backup lifting eye              | 23. Hinge module cover                | 33. Bracket table mounting plate         |
| 12. Hinge deck side mount             | 24. T-track-alum. 25mm                | 34. Traveler car                         |
| S/S tube                              | Plate sheet track                     | Block double control                     |
| Insert poptop                         | Stop end t-track Harken               | 35. Gudgeon aft mast support             |
| Bracket deck plastic white            | Car genoa alum.                       | 36. Window aft                           |
| Track slide                           | Stop t-track Harken                   | 37. Hatch W/screen & trim                |
| Track S/S poptop                      | 25. U-bolt w/base pad                 | 38. Bracket outboard                     |
| Track end                             | 26. Hasp Perko                        | 39. Gudgeon transom                      |
|                                       | 27. Camcleat plastic                  |  |

## Deck layout C28 CR (part2)

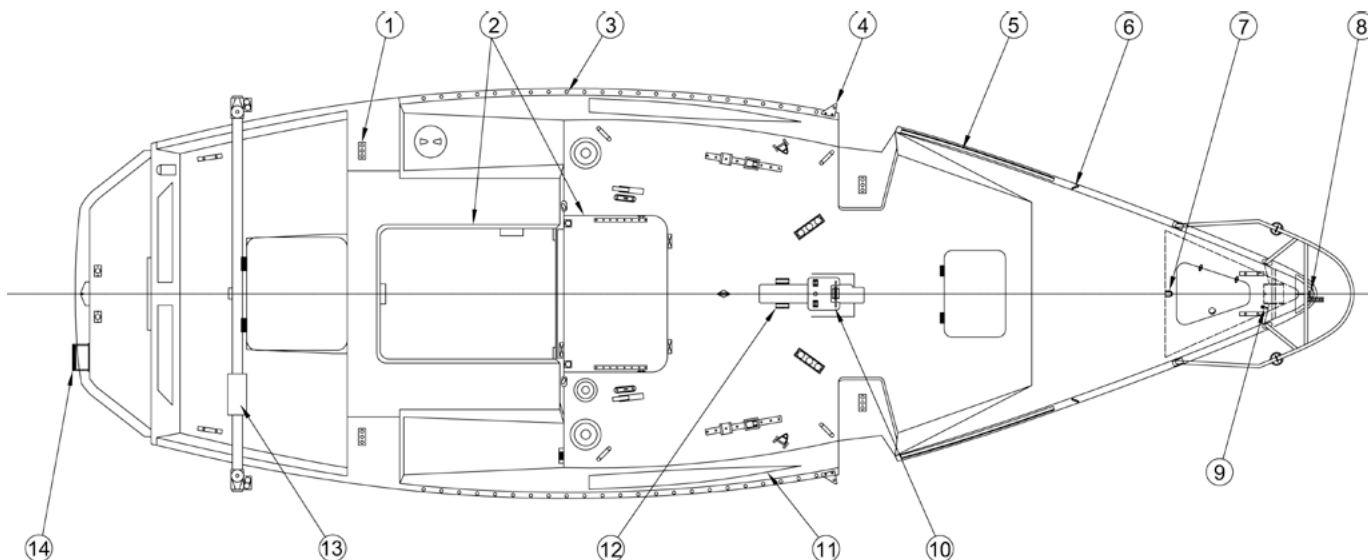

- |   |  |  |
|---|--|--|
| 1. Bracket folding upper strut<br>Pad bolt S/S  | Pin rigging<br>Beam retaining bracket<br>Rod polyurethane cast | 9. Block stand-up<br>Rope 6mm black          |
| 2. Trim edging 1/4" white pebble  | 5. Bow toe rail  | 10. Mast base                                |
| 3. Wing net rope retainer white   | 6. Eye strap RF134   | 11. Window side large                        |
| 4. Beam retaining plate cabin<br>Chain (pin retaining)<br>Chain ends white eye<br>Split rings | 7. U-bolt (inside anchor well)                                 | 12. Hinge deck 90°<br>Pin detent 1/4"x1-1/2" |
|   | 8. Bow roller w/chain plate<br>Sheave bow roller               | 13. Rope 8mm                                 |
|   |  | 14. Pads outboard bracket                    |

## Float layout C28 CR

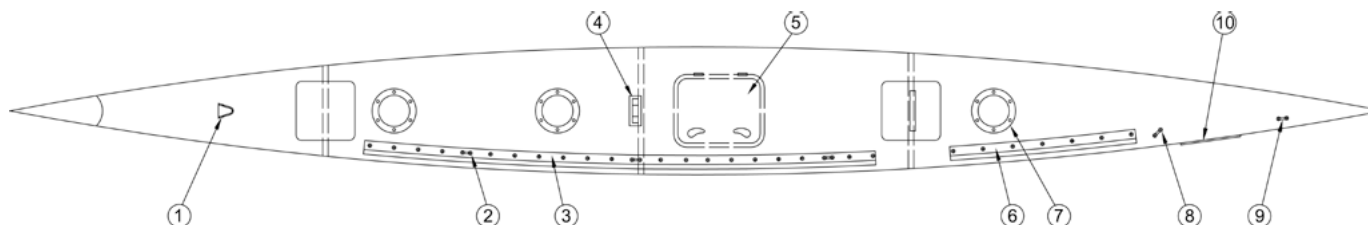

- |                     |                           |                     |
|---------------------|---------------------------|---------------------|
| 1. Vent midget      | Cover chain plate         | 8. Eye saddle RF134 |
| 2. Eye strap        | 5. Hatch 30 low profile   | 9. Eye strap RF528  |
| 3. Rail 28 wing net | 6. Rail 24 bow net 38"    | 10. Non-skid        |
| 4. Chain plate      | 7. Hatch 6" Viking/Becson |                     |

## Deck layout C28 CE (part1)

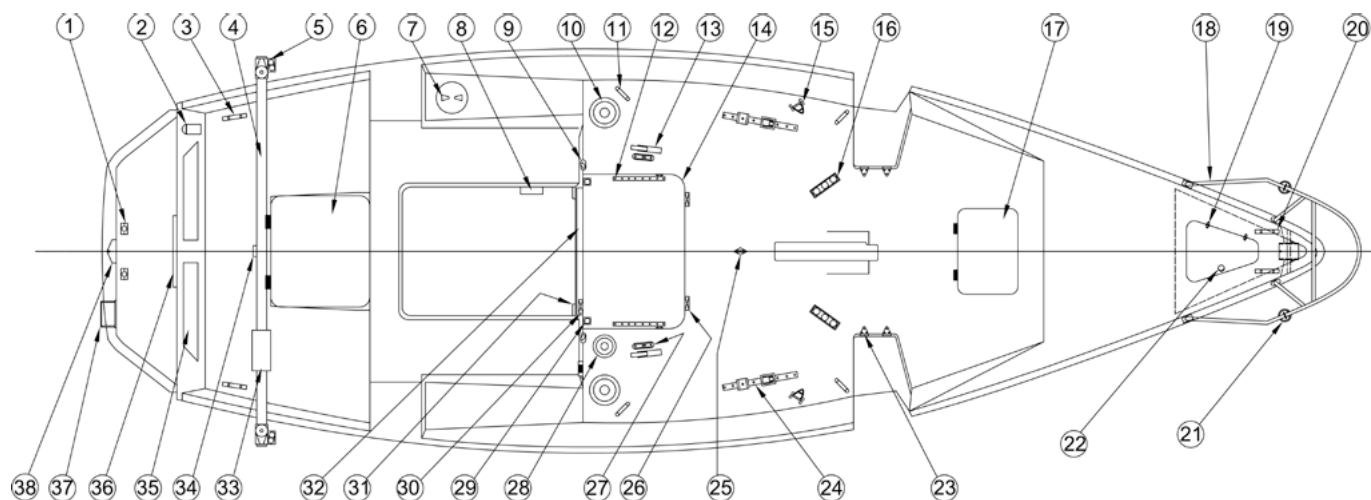

- |                                       |                                       |  |
|---------------------------------------|---------------------------------------|--|
| 1. Collar aft mast support            | Track stop                            | Plate backup winch                     |
| Pipe PVC 1-1/4" aft mast              | Nut #10 barrel Beckson chrome         | 28. Winch B32.2 STD self tailing       |
| Cap PVC aft mast support tubes        | 13. Rope clutch single Spinlock       | Plate backup winch                     |
| 2. Light LED stern                    | Plate backup rope clutch              | 29. Bracket deck plastic white         |
| Bracket stern light                   | 14. Trimloc 3/16" poptop black w/seal | Insert poptop                          |
| 3. Cleat 8" chrome                    | 15. Eye strap w/ferrule               | Bushing poptop addition                |
| Plate backup cleat mooring            | Plate backup raising loop             | Bushing poptop                         |
| 4. Traveler track                     | Bushing nylon mast raising brackets   | S/S tube                               |
| Sub. drill and anodize traveler track | Cotter ring                           | Bracket poptop                         |
| Traveler horse end bracket            | Mast raising wire anchor loop         | Pin S/S quick 3/16" x 1-1/2"           |
| Cap end traveler                      | 16. Organize deck triple Harken       | Chain S/S                              |
| 5. Control traveler Pr                | Pad backup deck organizer             | Chain end with eye                     |
| 6. Hatch 60 low profile               | Plate backup triple organizer         | Sleeve brass retainer (for bead chain) |
| Hatch trim 60 white                   | 17. Hatch 44 fwd w/stay arm           | Nut 1/4" barrel Beckson chrome         |
| 7. Hatch 6" white                     | Hatch trim 44 white                   | Nut #10 barrel Beckson chrome          |
| 8. Winch handle pocket Seadog         | 18. Pulpit                            | 30. Plastic. 1/8" black hatch slide    |
| 9. Camcleat plastic                   | 19. Hinge anchor locker S/S           | Hatch main companionway lower          |
| Plate backup camcleat                 | 20. Cleat 8" chrome                   | Hatch main companionway top            |
| 10. Winch B40.2A two speed            | 21. Plate backup cleat mooring light  | 31. Hasp Perko                         |
| Plate backup winch                    | navigation port and stb               | Packing block lock UHMW poly           |
| 11. Lifting eye (U-bolt)              | 22. Latch flush pull black            | 32. Plate main hatch foot              |
| Plate backup lifting eye              | 23. Hinge module cover                | 33. Traveler car                       |
| 12. Hinge deck side mount             | 24. Track t-alum. 25mm                | Block double control                   |
| S/S tube                              | Plate sheet track                     | 34. Gudgeon aft mast support           |
| Insert poptop                         | Stop end t-track Harken               | 35. Window aft                         |
| Bracket deck plastic white            | Car genoa alum.                       | 36. Hatch w/screen & trim              |
| Track slide                           | Stop t-track Harken                   | 37. Bracket outboard                   |
| Track S/S poptop                      | 25. U-bolt w/base pad                 | 38. Gudgeon transom                    |
| Track end                             | 26. Hasp Perko                        |  |
|                                       | 27. Camcleat plastic                  |  |

## Deck layout C28 CE (part2)

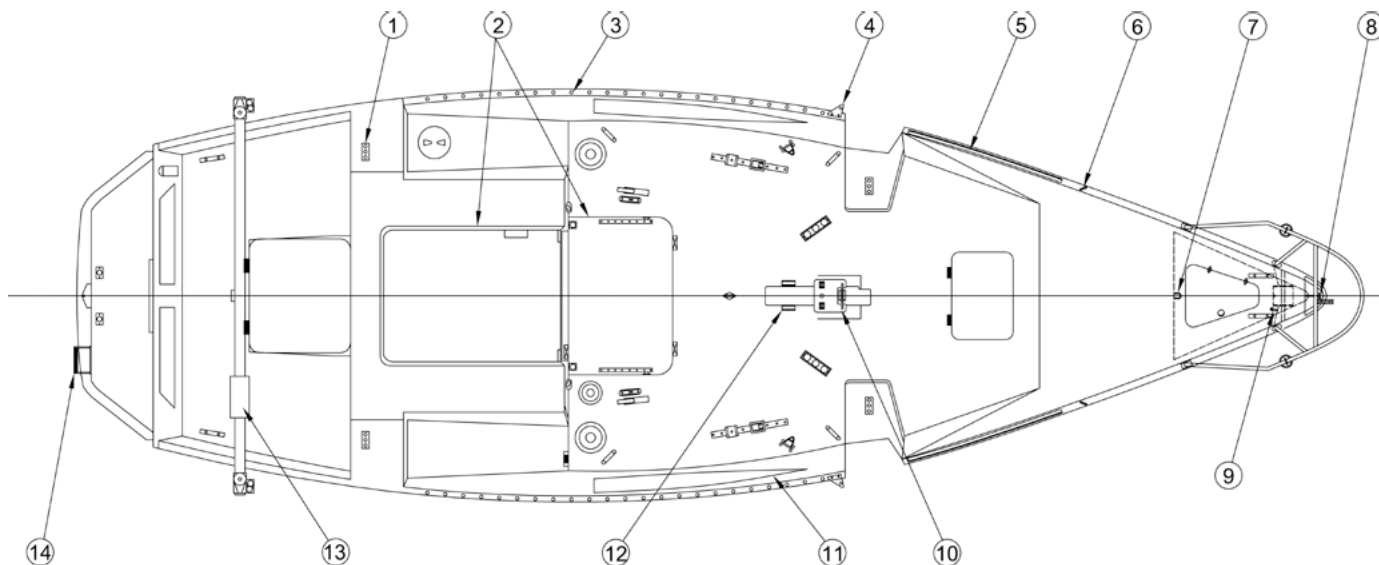

- |   |  |  |
|---|--|--|
| 1. Bracket folding upper strut<br>Pad bolt S/S  | Pin rigging<br>Beam retaining bracket<br>Rod polyurethane cast | 9. Block stand-up<br>Rope 6mm black          |
| 2. Trim edging 1/4" white pebble  | 5. Bow toe rail  | 10. Mast base                                |
| 3. Wing net rope retainer white   | 6. Eye strap RF134   | 11. Window side large                        |
| 4. Beam retaining plate cabin<br>Chain (pin retaining)<br>Chain ends white eye<br>Split rings | 7. U-bolt (inside anchor well)                                 | 12. Hinge deck 90°<br>Pin detent 1/4"x1-1/2" |
|   | 8. Bow roller w/chain plate<br>Sheave bow roller               | 13. Rope 8mm                                 |
|   |  | 14. Pads outboard bracket                    |

## Float layout C28 CE

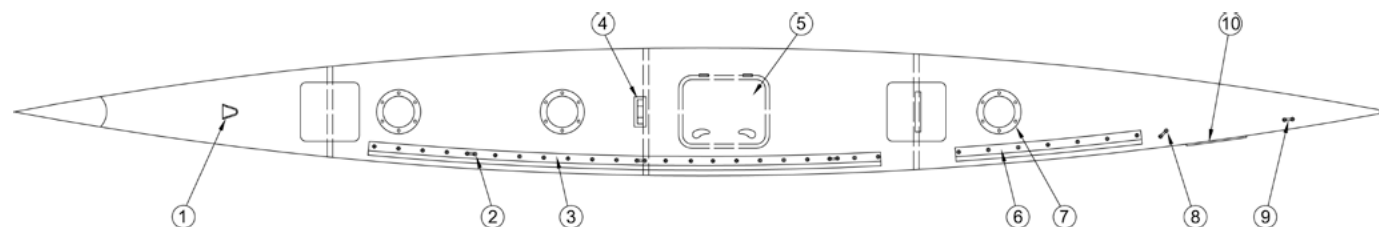

- |                     |                            |                     |
|---------------------|----------------------------|---------------------|
| 1. Vent midget      | 4. Chain plate             | 8. Eye saddle RF134 |
| 2. Eye strap        | 5. Hatch 30 low profile    | 9. Eye strap RF528  |
| 3. Rail 28 wing net | 6. Rail 24 bow net 38"     | 10. Non-skid        |
| 4. Chain plate      | 7. Hatch 6" Viking/ Becson |                     |

## Deck layout C31 RS (part1)

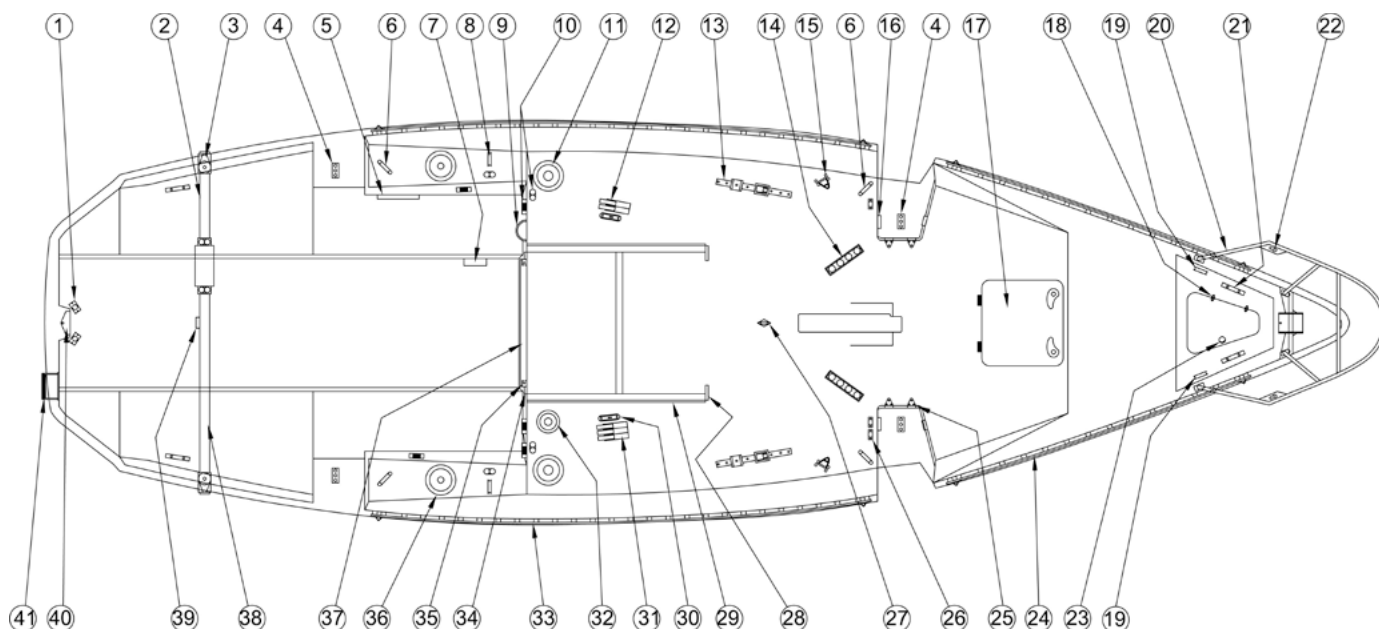

- |  |   |  |
|--|---|--|
| 1. Collar aft mast support<br>Pipe PVC 1-1/4" aft mast<br>Cap PVC aft mast support tubes                         | 15. Eye strap w/ferrule<br>Plate backup raising loop<br>Bushing nylon mast raising brackets<br>Mast raising wire anchor loop<br>Cotter ring | 28. Hatch slide end stop<br>29. Hatch slide companionway channel<br>Hatch slide alum angle<br>30. Camcleat plastic<br>Plate backup camcleat<br>31. Rope clutch XC triple<br>Plate backup spinlock clutch |
| 2. Traveler track<br>3. Control traveler Pr<br>4. Spacer beam bolt pad<br>Beam bolt pad                          | 16. Support pad beam well flap<br>17. Hatch 60 low profile<br>Hatch trim 60 white   | 32. Winch B32.2 self tailing<br>33. Rail wing net (hull side)<br>Spacer cabin wing net rail<br>Eye saddle  |
| 5. Hatch 6" white<br>6. Lifting eye (U-bolt)<br>Plate backup lifting eye   | 18. Cleat 8 chrome (bow and stern)<br>Plate backup cleat mooring  | 34. Hasp Perko<br>Packing block lock UHMW poly   |
| 7. Winch handle pocket Seadog<br>8. Block stand-up<br>9. Compass Danforth  | 19. Light navigation port/stb white led<br>20. Latch flush pull black<br>21. Hinge anchor locker S/S<br>22. Block stand-up                  | 35. Rail main hatch vertical side<br>Hatch board companionway upper<br>Hatch board companionway lower  |
| 10. Camcleat plastic<br>Plate backup camcleat<br>Wedge camcleat large  | 23. Pulpit<br>Plate backup pulpit   | 36. Winch B40.2A two sped<br>Plate backup winch  |
| 11. Winch B40.2 STA self tailing<br>Plate backup winch   | 24. Rail bow net 88"<br>Spacer cabin wing net rail<br>Eye saddle  | 37. Plate foot companionway threshold<br>Trim companionway hatch trim<br>HDPE  |
| 12. Rope clutch XC double spinlock<br>Plate backup spinlock clutch   | 25. Hinge module cover  | 38. Traveler car<br>Block double control   |
| 13. T-track alum. 25mm<br>Plate sheet track<br>Stop end t-track Harken<br>Car genoa alum.<br>Stop t-track Harken | 26. Fairlead nylon<br>Plate backup fairlead   | 39. Gudgeon aft mast support<br>40. Gudgeon transom  |
| 14. Organizer quad Spinlock  | 27. U-bolt w/base pad<br>Plate backup U-bolt  | 41. Bracket outboard   |



## Deck layout C31 RS (part2)

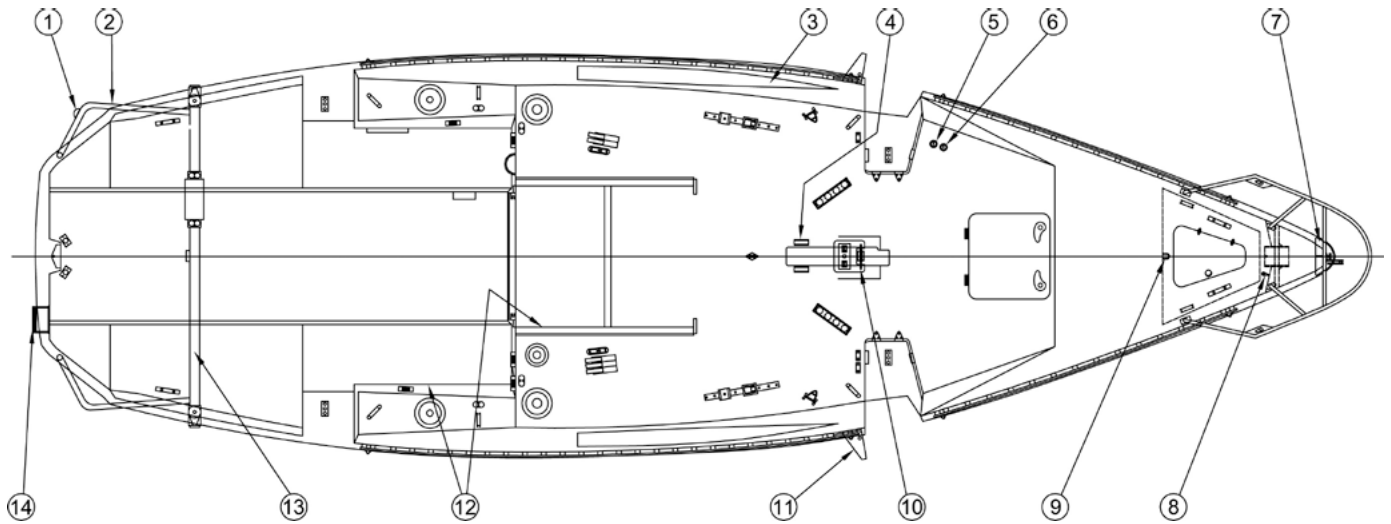

- |                           |                                  |                                   |
|---------------------------|----------------------------------|-----------------------------------|
| 1. Light LED stern        | 7. Bow roller Assembly           | Bracket beam retaining left       |
| 2. Pushpit                | Sheave bow roller                | Bracket hull beam retaining right |
| 3. Window main cabin      | 8. Block stand-up                | Bracket hull beam retaining left  |
| 4. Hinge deck 90°         | Rope 6mm black                   | Pad spacer beam retaining         |
| Pin detent 1/4"x 1-1/2"   | 9. U-bolt                        | 12. Trim edging 1/2" white pebble |
| 5. Deck fill water Seadog | 10. Mast base                    | 13. Traveler line                 |
| 6. Deck fill waste Seadog | 11. Bracket beam retaining right | 14. Pad outboard bracket HDPE     |

## Float layout C31 RS

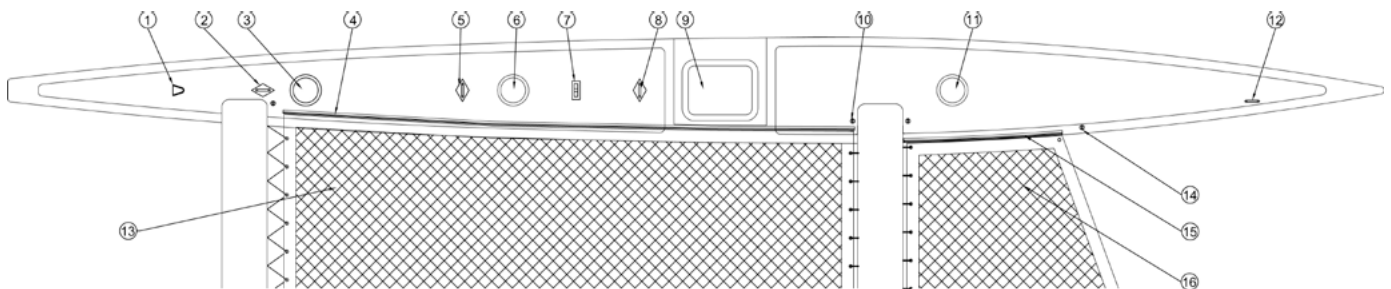

- |                  |                   |                  |
|------------------|-------------------|------------------|
| 1. Vent midget   | 7. Chain plate    | 12. U-bolt       |
| 2. U-bolt        | Cover chain plate | 13. Net wing     |
| 3. Hatch 6"      | 8. U-bolt         | 14. Eye strap    |
| 4. Rail wing net | 9. Hatch          | 15. Rail bow net |
| 5. U-bolt        | 10. Eye-bolt      | 16. Bow net      |
| 6. Hatch 6"      | 11. Hatch 6"      |                  |

## Deck layout C31 CR/UC (part1)

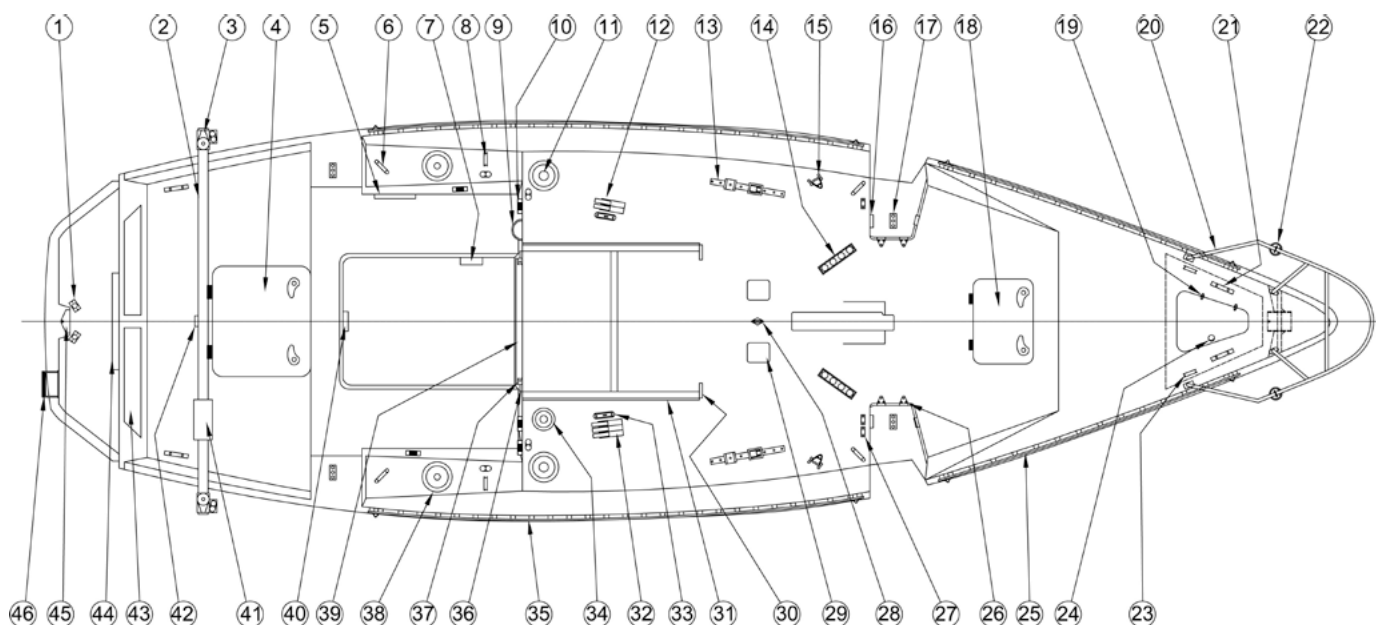

- |  |  |   |
|--|--|---|
| 1. Collar aft mast support<br>Pipe PVC 1-1/4" aft mast<br>Cap PVC aft mast support tubes                               | 15. Eye strap w/ferrule<br>Plate backup raising loop<br>Bushing nylon mast<br>Mast raising wire anchor loop<br>Cotter ring | 31. Hatch slide companionway<br>Hatch slide alum angle  |
| 2. Traveler track long version<br>Traveler horse long version<br>Cap end traveler track                                | 16. Support pad beam well flap   | 32. Rope clutch XC triple<br>Plate backup spinlock clutch   |
| 3. Control traveler Pr   | 17. Spacer beam bolt pad<br>Beam bolt pad  | 33. Camcleat plastic<br>Plate backup camcleat   |
| 4. Hatch 60 low profile  | 18. Hatch 30 low profile float<br>Hatch trim white   | 34. Winch B32.2 self tailing<br>Plate backup winch B32.2 self tailing                                 |
| 5. Hatch trim 60 white   | 19. Hinge anchor locker S/S  | 35. Rail wing net (hull side)<br>Spacer cabin wing net rail<br>Eye saddle                             |
| 6. Lifting eye (U-bolt)<br>Plate backup lifting eye  | 20. Pulpit<br>Plate backup pulpit  | 36. Hasp Perko<br>Backing block lock UHMW poly  |
| 7. Winch handle pocket Seadog  | 21. Cleat 8 chrome (bow and stern)<br>Plate backup cleat mooring   | 37. Rail main hatch vertical side<br>Hatch board companionway upper<br>Hatch board companionway lower |
| 8. Block stand-up  | 22. Light navigation port and stb  | 38. Winch B40.2A two speed<br>Plate backup winch  |
| 9. Compass Danforth  | 23. Block stand-up   | 39. Plate foot companionway threshold<br>Trim companionway hatch trim                                 |
| 10. Camcleat plastic<br>Plate backup camcleat<br>Wedge camcleat large  | 24. Latch flush pull black   | 40. Bracket table mounting plate  |
| 11. Winch B40.2 self tailing<br>Plate backup winch   | 25. Rail bow net 88"<br>Spacer cabin wing net rail<br>Eye saddle   | 41. Traveler car<br>Block double control  |
| 12. Rope clutch XC double spinlock<br>Plate backup spinlock clutch   | 26. Hinge module cover Fairlead nylon  | 42. Gudgeon aft mast support  |
| 13. T-track aluminum<br>Plate sheet track<br>Stop end t-track Harken<br>Car genoa lead aluminum<br>Stop t-track Harken | 27. Plate backup<br>Fairlead   | 43. Window aft cabin  |
| 14. Organizer Quad spinlock<br>Plate backup quad organizer<br>Pad deck organizer quad                                  | 28. U-bolt w/base pad<br>Plate backup U-bolt   | 44. Hatch w/screen & trim   |
|  | 29. Hatch deck<br>Trim ring hatch deck   | 45. Gudgeon transom   |
|  | 30. Hatch slide end stop   | 46. Bracket outboard  |

## Deck layout C31 CR/UC (part2)

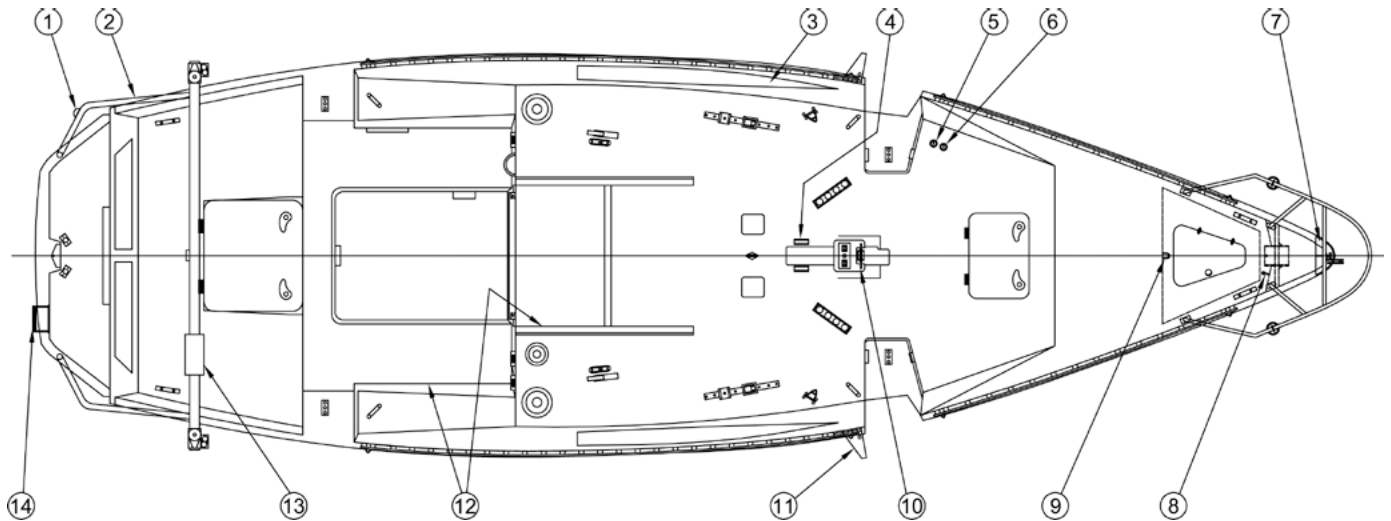

- |   |   |                                   |
|---|---|-----------------------------------|
| 1. Light LED stern                            | 7. Bow roller assembly<br>Sheave bow roller | Bracket beam retaining left       |
| 2. Pushpit                                    | 8. Block stand-up<br>Rope 6mm black         | Bracket hull beam retaining right |
| 3. Window main cabin                          | 9. U-bolt                                   | Bracket hull beam retaining left  |
| 4. Hinge deck 90°<br>Pin detent 1/4" x 1-1/2" | 10. Mast base                               | Pad spacer beam retaining         |
| 5. Deck fill water Seadog                     | 11. Bracket beam retaining right            | 12. Trim edging 1/4" white pebble |
| 6. Deck fill waste Seadog                     |   | 13. Traveler line                 |
|   |   | 14. Pad outboard bracket HDPE     |

## Float layout C31 CR/UC

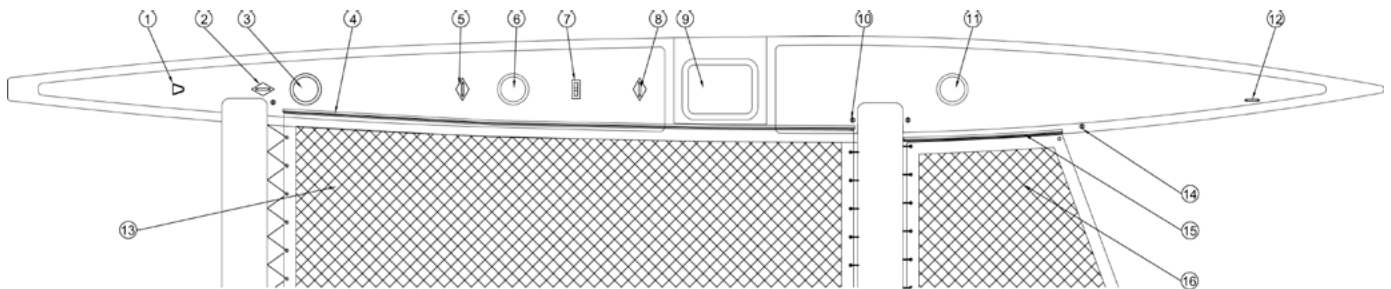

- |                  |                                     |                  |
|------------------|-------------------------------------|------------------|
| 1. Vent midget   | 7. Chain plate<br>Cover chain plate | 12. U-bolt       |
| 2. U-bolt        | 8. U-bolt                           | 13. Net wing     |
| 3. Hatch 6"      | 9. Hatch                            | 14. Eye strap    |
| 4. Rail wing net | 10. Eye-bolt                        | 15. Rail bow net |
| 5. U-bolt        | 11. Hatch 6"                        | 16. Bow net      |
| 6. Hatch 6"      |                                     |                  |

## Deck layout Cruze 970

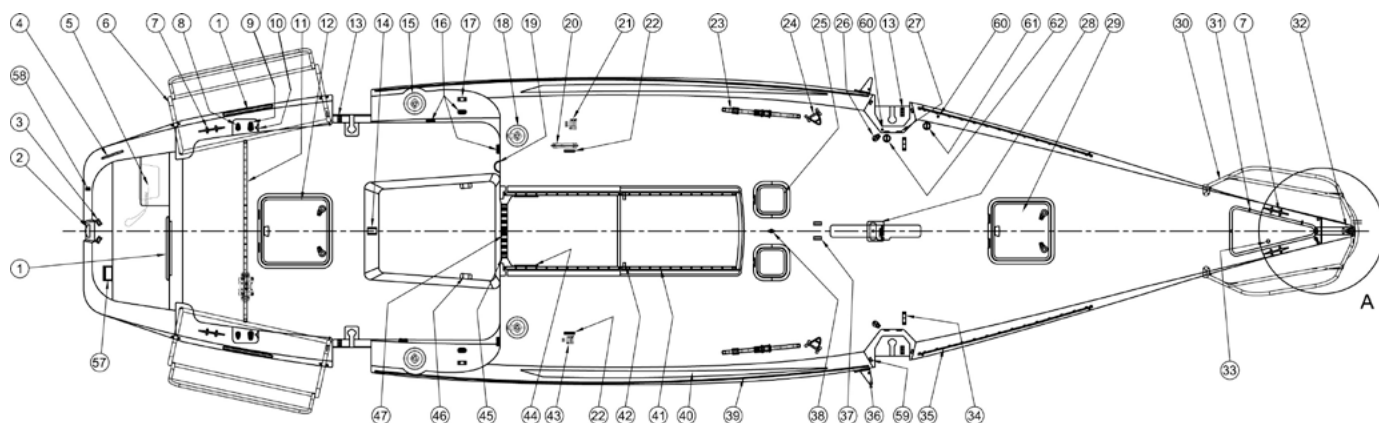

Detail A

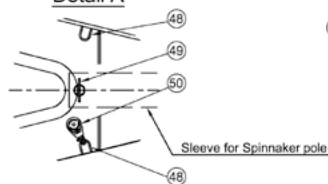

Spinnaker pole



- |  |   |   |
|--|---|---|
| 1. Port light Atlantic sw30  | 22. Camcleat  | 38. U-bolt w/base pad   |
| 2. Rudder gudgeon  | 23. T-track Alum.<br>Car genoa alum.  | 39. Rail wing net (hull side)<br>Spacer cabin wing net rail   |
| 3. Collar aft mast support<br>Pipe PVC 1-1/4" aft mast support<br>socket<br>Cap PVC aft mast support tubes | 24. Eye strap w/ferrule<br>Bushing nylon mast raising brackets<br>Stop end t-track Harken   | 40. Side window   |
| 4. Hand rail transom   | 25. Hatch deck<br>Trim ring hatch deck  | 41. Rails companion way alum.   |
| 5. Transom shower  | 26. Cheek block 2.25 H013   | 42. Bracket mounting companion way<br>angle   |
| 6. Pushpit   | 27. Hinge module cover  | 43. Spinlock jammer SUA/2   |
| 7. Cleat 8" chrome   | 28. Mast step pivot ball<br>Cotter pin 1/8"<br>Mast base plate  | 44. Handle for corner   |
| 8. Control traveler  | 29. Hatch 40 w/stay arm   | 45. Washboard aft support rail<br>Washboard fwd support rail  |
| 9. Block 40mm  | 30. Pulpit  | 46. Winch handle pocket   |
| 10. Eyes trap RF1055   | 31. Hinge anchor locker   | 47. Plate companion foot  |
| 11. Track mainsheet traveler<br>Track end<br>Main sheet traveler car stopper<br>Traveler car               | 32. Fitting forestay  | 48. Bolt RF544  |
| 12. Hatch alum. medium<br>Hatch trim kit for 70<br>Stay telescopic retrofit kit                            | 33. Latch flush pull black  | 49. Spin. pole retaining pin 3/4" x 6"  |
| 13. Spacer beam bolt pad<br>Beam bolt pad  | 34. Fail lead 2 holes alum. black   | 50. Single block  |
| 14. Bracket table mounting plate   | 35. Rail bow net 88"<br>Spacer cabin wing net rail<br>Eye saddle  | 51. Fairlead nylon  |
| 15. Winch B40.2A two speed   | 36. Bracket beam retaining right<br>Bracket beam retaining left<br>Bracket hull beam retaining right<br>Bracket hull beam retaining left<br>Pad spacer beam retaining | 52. Bracket spin. pole launch HDP   |
| 16. Camcleat plastic<br>Wedge camcleat large   | 37. Hinge deck 90°<br>Pin detent 1/4" x 1-1/2"  | 53. Pole spin. carbon   |
| 17. Fairlead nylon   |   | 54. Spin. pole end fitting  |
| 18. Winch B40.2 STA self tailing<br>Plate backup winch   |   | 55. Spring stand-up bow spin pole<br>Block RF868 spin pole<br>Eye strap RF 868 spin pole<br>Eye strap RF528 |
| 19. Compass Danforth   |   | 56. Cover spin. pole sleeve   |
| 20. Rope clutch single XC  |   | 57. Bracket outboard  |
| 21. Spinlock jammer SUA/3  |   | 58. Ladder boarding 3 step  |
|  |   | 59. Support pad beam well flap  |
|  |   | 60. Vent gas tank chrome  |
|  |   | 61. Deck fill water Seadog  |
|  |   | 62. Deck fill waste   |

## Float layout Cruze 970

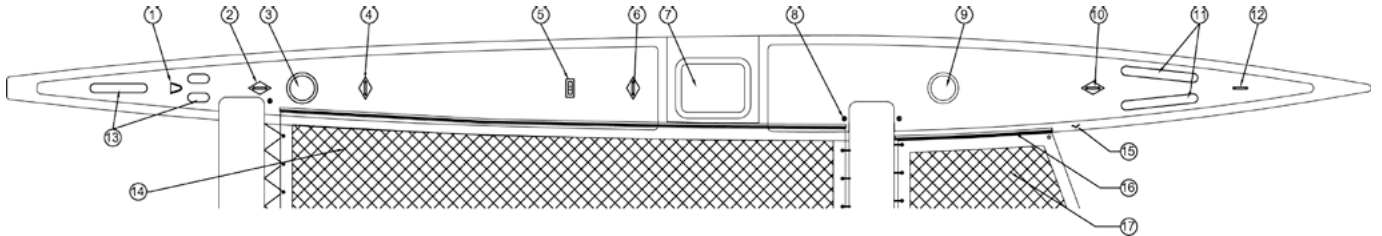

- |                                  |                    |                    |
|----------------------------------|--------------------|--------------------|
| 1. Vent midget                   | 7. Hatch           | 13. Non-skid strip |
| 2. U-bolt                        | 8. Eye-bolt        | 14. Wing net       |
| 3. Hatch 6"                      | 9. Hatch 6"        | 15. Eye strap      |
| 4. U-bolt                        | 10. U-bolt         | 16. Rail bow net   |
| 5. Cover chain plate/chain plate | 11. Non-skid strip | 17. Net bow        |
| 6. U-bolt                        | 12. U-bolt         |                    |

## Deck layout C37 CR/RS (part1)

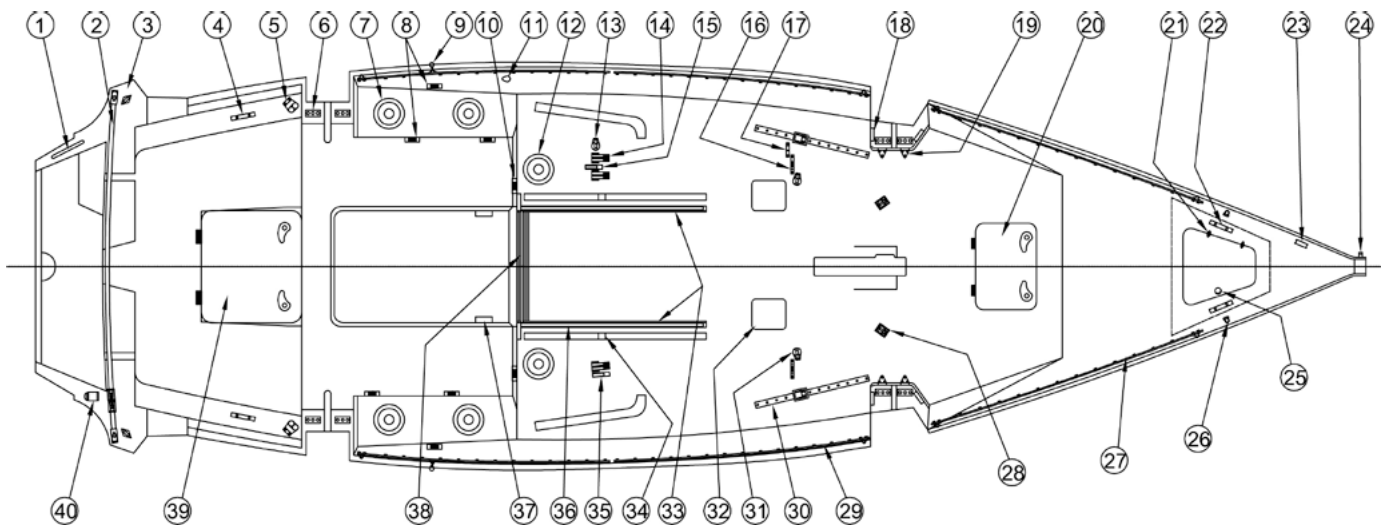

- |                                   |  |   |
|-----------------------------------|--|---|
| 1. Rail hand transom              | 13. Block cheek                          | 28. Backing block for cheek block             |
| 2. Traveler track                 | Nut barrel flange & knurled #10          | Block cheek                                   |
| Control traveler port/stb         | 14. Rope clutch single                   | Eye strap                                     |
| Traveler car                      | Nut barrel flange & knurled 1/4"         | Nut barrel flange & knurled #10               |
| Block double control              | 15. Rope clutch single Spinlock XAS/1    | 29. Rail hull wing net 79" & 85"              |
| Coupler traveler cars             | Nut barrel flange & knurled #10          | Spacer cabin wing net rail                    |
| 3. Pad diamond large              | 16. Fairlead nylon                       | Eye strap                                     |
| 4. Cleat 8" chrome                | Nut barrel flange & knurled #10          | 30. T-track alum. w/pin stop                  |
| 5. Cleat cam w/ swivel base       | 17. Fairlead 2 hole alum. black 2 pieces | Stop end t-track                              |
| 6. Pad beam bolt                  | Nut barrel flange & knurled #10          | Nut barrel flange & knurled 5/16"             |
| 7. Winch B42.2A                   | 18. Support pad beam well flap           | 31. Block cheek                               |
| Plate backup 26 3/8"x6"x6"        | 19. Hinge module cover                   | Nut barrel flange & knurled #10               |
| 8. Camcleat plastic               | 20. Hatch 60 low profile                 | Eye strap RF1055                              |
| Wedge camcleat large              | 21. Hinge anchor locker                  | 32. Hatch deck 11x11                          |
| Plate backup camcleat             | 22. Cleat 8" chrome                      | 33. Handle main Hatch                         |
| 9. Block stand-up barber hauler   | 23. Block stand-up barber hauler         | 34. Bracket mounting companionway angle       |
| 10. Camcleat plastic              | 24. Fairlead 2 hole alum. black 2 pieces | 35. Rope clutch single XC Spinlock XCS0608/1W |
| Wedge camcleat large              | 25. Latch flush mount pull white         | 36. Rail companionway alum.                   |
| Nut barrel flange and knurled #10 | 26. U-bolt RF544                         | 37. Winch handle pocket Seadog                |
| 11. Vent gas tank chrome zinc     | 27. Rail bow net 88"                     | 38. HDPE hatch guide wide vertical            |
| 12. Winch B40.2 STA self tailing  | Spacer cabin wing net rail               |   |
| Nut barrel flange & knurled 1/4"  | Eye strap                                |   |

Plate companionway foot  
 Hatch companionway smoked  
 Hasp Perko

Packing block lock UHMW poly  
 39. Hatch alum. medium  
 40. Light LED stern

Bracket stern light

### Deck layout C37 CR/RS (part2)

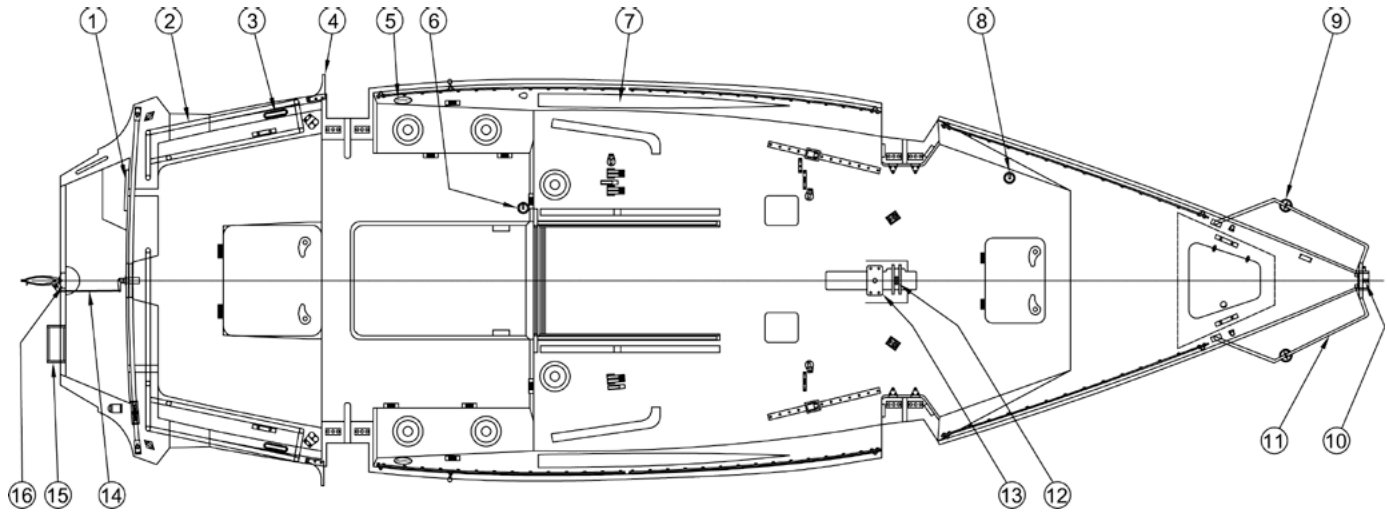

- |  |  |                              |
|--|--|------------------------------|
| 1. Hatch Sz2 opening port with               | Rod polyurethane cast                    | 10. Plastic pipe             |
| 2. Pushpit port                              | 5. Graphic Corsair "carbon" style raised | 11. Pulpit                   |
| Pushpit starboard                            | 6. Deck fill water Seadog                | 12. Sheave 1/2" x 1-1/2"     |
| 3. Hatch Sz2 opening port with screen & trim | 7. Window main cabin P & S (4pcs)        | Spacer daggerboard sheave    |
| 4. Bracket beam lock (hull) r. hand          | Trim ring saloon window fwd stb          | Organizer bar D/B line (fwd) |
| Bracket beam lock (hull) l. hand             | Trim ring saloon window mid stb          | Organizer bar D/B line (aft) |
| Bracket beam lock (beam) r. hand             | Trim ring saloon window aft stb          | Pin D/B organizer            |
| Bracket beam lock (beam) l. hand             | Trim ring saloon window fwd port         | 13. Mast base                |
| Pin beam lock                                | Trim ring saloon window mid port         | 14. Steering system          |
| Chain (pin retaining)                        | Trim ring saloon window aft port         | 15. Outboard bracket         |
| Chain ends with eye                          | 8. Deck fill waste Seadog                | 16. Rudder gudgeon           |
| Split rings                                  | 9. Light navigation port and stb         | Rudder case pin              |

### Float layout C37 CR/RS

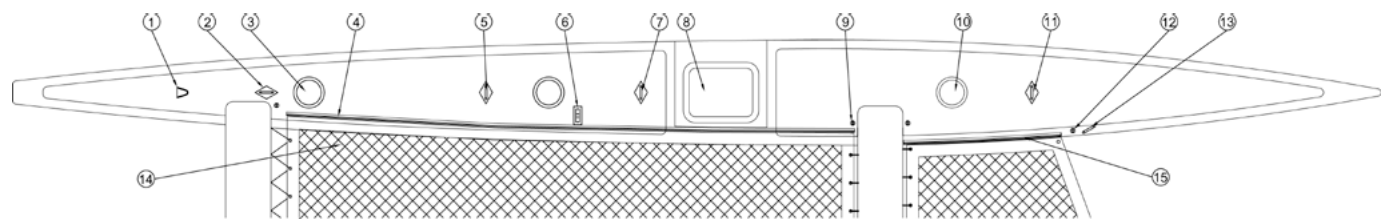

- |                      |              |                  |
|----------------------|--------------|------------------|
| 1. Vent midget       | 8. U-bolt    | 15. U-bolt       |
| 2. U-bolt            | 9. Hatch     | 16. Eye-bolt     |
| 3. Hatch 6"          | 10. Eye-bolt | 17. U-bolt       |
| 4. Rail wing net     | 11. Hatch 6" | 18. Net wing     |
| 5. U-bolt            | 12. U-bolt   | 19. Rail bow net |
| 6. Cover chain plate | 13. Eye-bolt |                  |
| 7. Chain plate       | 14. Hatch 6" |                  |

## TYPICAL TRAILER SETUP

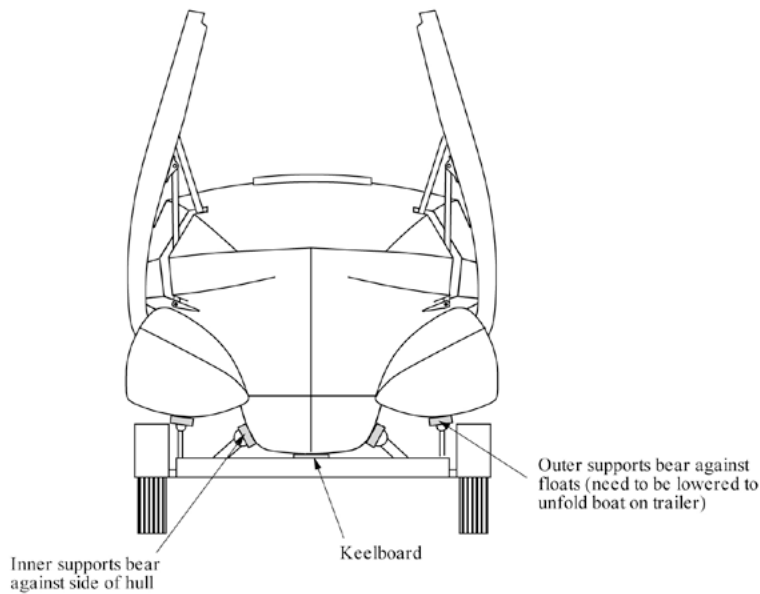

**All supports should bear evenly and equally against boat**

**\*Note:**  
The main hull should bear all weight  
The out supports are to support the floats so the boat does not roll side to side on a trailer.

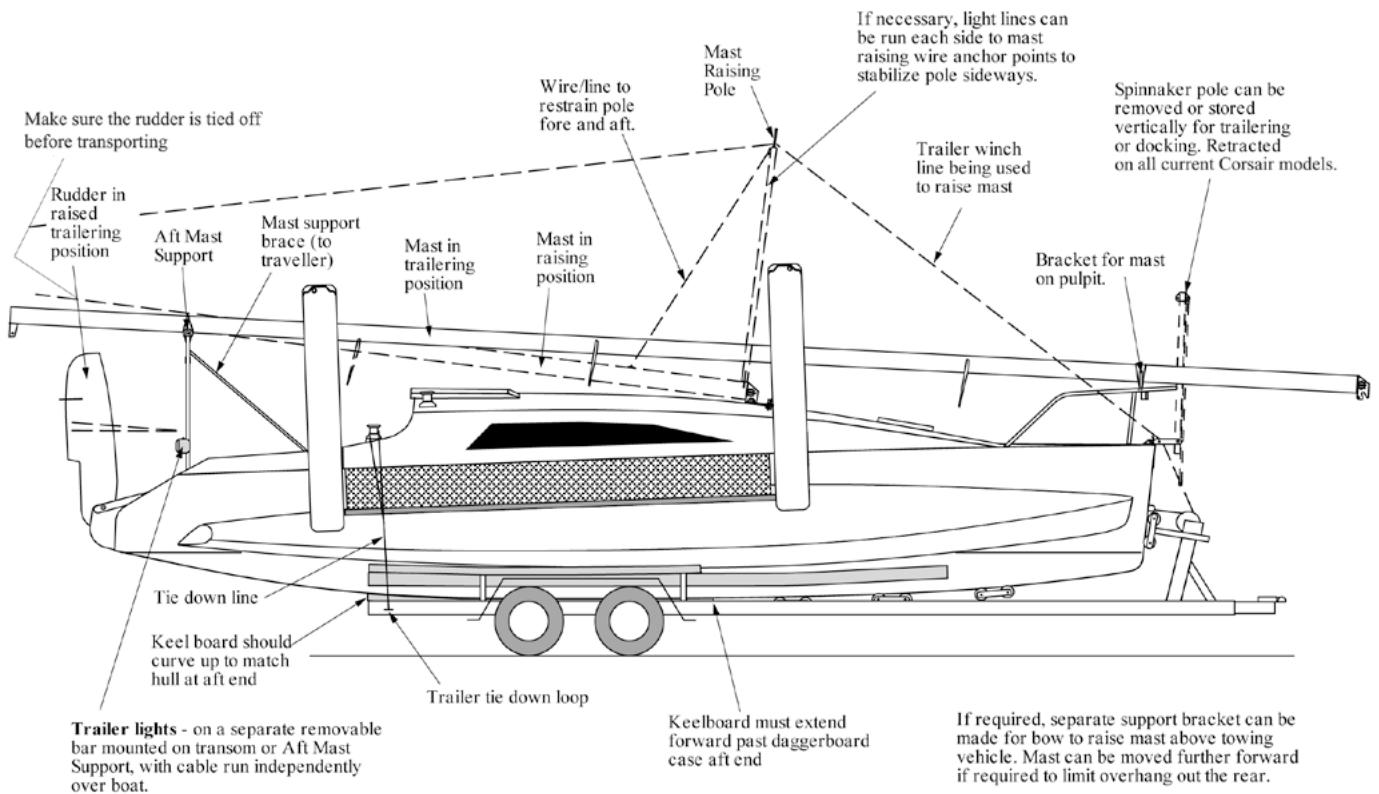

**Always check that trailering setup complies with local regulations**

## MAINTENANCE & SAFETY CHECKLIST

For continued safe and enjoyable operation, it is essential that regular maintenance be carried out. Trimarans are actually more like aircraft in many aspects and it is important to conduct regular maintenance and safety checks to locate any potential problems before they become serious.

The following Maintenance safety check sheet has thus been developed and it is strongly recommended that a full check be undertaken every 6 months.

In general, after every sail, the complete boat and trailer should always be thoroughly washed down with fresh water. This is very important to keep that new look and to prevent rust taking hold on the trailer. Particularly, wash out the brakes and suspension area of the trailer. Regularly check the bilges of the center hull and the floats for any water. Sails should always be rolled up or folded (the same way as you receive them) - dried first if wet. If possible, keep your boat under cover as this will ensure the finish keeps its gloss for the life of the boat. Even the best gel coat finish will eventually begin to fade. Polishing your Corsair Trimaran once a year will maintain the gel coat shine and strengthen the gel coat surface.

## MAST

- Masthead sheaves should turn freely and clevis or pivot pins should not be worn or show signs of distortion.
- Spinnaker halyard and Jib halyard sheaves should turn freely, and clevis or pivot pins should not be worn or show signs of distortion.
- Forestay tab/nose should be checked for any cracks or signs of distortion.
- All other stay attachments to mast should be checked for distortion or corrosion.
- Mast step should be checked for any distortion or cracks.
- Mast step sheaves should turn freely, and clevis or pivot pins should not be worn or show signs of distortion.
- Boom gooseneck pins should be checked for any signs of wear or distortion.

## RUNNING RIGGING

- All halyards should be checked for broken strands or wear; particularly where they enter the mast when sails are up and where rope clutches engage. A sleeve over rope tail at rope clutch area can prolong life and give better clutch holding power.
- Spinnaker halyard should have any worn area at the top cut out and the halyard retied or spliced to the snap shackle.

## STANDING RIGGING

- All stays should be checked for broken strands or corrosion, particularly at end stages. If any stays are badly kinked, replacement should be considered. Stainless steel is prone to fatigue and in a trailer boat it is not uncommon to get kinks in the stays while rigging or de-rigging which further fatigues the wire. Check all turnbuckles for corrosion and that all locking rings or pins are in place and work correctly.

## HULLS

- Check bow U-bolt and spinnaker eye for any movement.
- Check all chain plates for any signs of movement.
- Check deck to hull joints where visible for any delamination or cracking in joint.
- Check wing nets, particularly eyelets for wear.

Wing nets should be replaced every three or four years. The taped edges are usually the first to fail and sometimes just redoing these will extend the net life. If replacing nets, avoid any close weave fabrics as these can trap wind underneath creating unwanted lift. Bow nets in particular should always be of a very open weave.

- Check rudder case for any sign of stress cracks or corrosion, particularly at lower end. Rudder blade should swing up and down easily in case but without any slop.
- Check rudder blade or shaft around bottom edge of rudder case for any stress cracks. Replace if necessary.
- Check leading and trailing edges of rudder blade for any de-lamination or splitting.
- Check rudder control lines for wear and replace pull down line every year.
- Check dagger board around bottom edge of hull for any stress cracks.
- Check leading and trailing edges of dagger board for any de-lamination.
- Check control lines for wear and replace if necessary.
- Check traveler welds for any signs of cracking.
- Check hull area around lower folding strut brackets for any signs of damage/cracking.
- On early model F-31s check around main hull/deck join flange just under forward beams for any cracking in joint.
- Check all deck fitting for any cracks or wear.



## BEAMS

- Check all beam joint flanges for any sign of delamination or cracking. It is not uncommon to find hairline cracks in the gel coat surface in high load areas, but continue to monitor.

### WARNING

*(Any de-lamination or cracking in beam flanges should be regarded as serious and must be repaired without delay. Otherwise a small crack can grow until it can cause failure.)*

- Check top non-skidded surface of beams for any movement or 'softness' under foot, or if 'oil canning' or ripping of the top beam surface can be observed while sailing. This must be inspected and repaired immediately as this could be a serious fault.
- Check that plastic compression pads remain on inner ends of beams and that they bear against deck/hull when floats are extended. Also check around this area for any signs of damage or cracking on both deck/hull and beam.
- Lightly grease beam bolt threads with a teflon grease.

## FOLDING SYSTEM

- Check all pivot pins for corrosion and that circlips or nuts are properly fitted.
- Check hull and beam brackets for any looseness or cracking.
- Check all folding struts have plastic bushes at pivot points and that there are no major cracks in welds (these welds are not structurally important and small cracks are not significant - these result from flex during folding).
- Check locking pins (for when floats are retracted) and brackets for excessive wear. Rubber stops should be replaced if worn excessively.
- Check that floats do not bear directly on to the main hull. There should be a bumper on the hull side or a minimum 1/8" gap.

## TRAILER

- Check trailer winch line for wear.

### CAUTION

*(When raising the mast by using the winch there is considerable tension on the jib halyard and winch line. Be doubly careful when checking these for wear as failure of either one could result in severe injury.)*

- Check all trailer supports bear evenly against hulls.
- Trailer should be regularly cleaned and oiled.
- Check wheel bearing for wear.
- Check operation of brakes.

Any defects or problems found during this check should be remedied immediately.

This checklist is intended as a guide only and may not cover every potential problem. Owner should always check every aspect of boat on a regular basis.

# CORSAIR DEALERS WORLDWIDE

## USA

### Carolinas

North Carolina, South Carolina, Florida

Steve Marsh  
Tanya Franchi  
Finish Line Of The Treasure Coast, Inc.  
3707 SE Dixie Highway, Stuart,  
FL 34997, USA  
crew@finishlineotc.com

### Atlantic North East

New York, New England, Pennsylvania,  
New Jersey to Canadian border

Bob Gleason  
The Multihull Source inc.  
3 narrows road P.O. box 95, Wareham,  
MA 02571, USA  
sailfast@themultihullsource.com

### Gulf Coast

Florida Panhandle, West Apalachee  
Bay, West Georgia (incl. Atlanta),  
Alabama, Mississippi, Louisiana,  
Tennessee

Donald Wigston  
Windcraft Multihulls  
120 Point Comfort Rd, Mary Esther  
FLORIDA 32569 USA  
info@windcraft.net  
phone: 404 307 9121  
toll free 877 358 9979

### Pacific Mid West

Northern California incl. San Francisco,  
Northern Nevada

Gary Helms  
Adam Helms  
Helms Yacht Sales  
314 Tideway, Alameda, CA 94501,  
San Francisco, USA  
garyhelms@gmail.com  
adamleehelms@gmail.com

### Pacific South West

Southern California incl. San Diego &  
Los Angeles, Arizona, Southern Nevada

Kurt Jerman  
Monte Cottrell  
West Coast Multihulls  
2330 Shelter Island Dr  
Suite 203 San Diego  
CA 92106, USA  
kurt@westcoastmultihulls.com  
monte@westcoastmultihulls.com  
T: 619 571 3513

### Texas, Oklahoma

Richard Clary  
La Vida Starships  
1792 North Stemmons Freeway,  
Lewisville, TX 75067, USA  
lvstx@verizon.net EUROPE

## EUROPE

### Finland

Matti Helenius  
Sailman Northern Lights  
Paakkistentie 5,  
21290 Rusko, Finland  
matti.helenius@northernyachts.fi

### France North

Antoine Jouselin  
Plaisance Nautic  
4 ZA du Rédo,  
56640 Arzon, France  
antoine@plaisancenauticservices.fr

### France South

Christian Malardeau  
Plaisance Nautic  
Rue des Charmes, Marcilly en Villette,  
F-45240, France  
c.malardeau@corsairmarine.fr

### Germany North and Central

Christoph Wentland  
Yacht-Netze  
Bahnhofstr. 3, Gronau (Leine),  
31028, Germany  
Info@Yacht-Netze.de

### Germany South, Austria, Switzerland

Werner Stolz  
Cornelia Klapprott  
Corsair Deutschland  
Wettersteinstrasse 16, Taufkirchen,  
D82024, Germany  
aws-werner.stolz@t-online.de  
cornelia.klapprott@t-online.de

### Holland

The Netherlands, Belgium, Luxembourg

Chris Minnee  
Jan De Boer Catamarans  
J. Van Der Perkstraat 4, 2223 BT,  
Katwijk, Holland  
info@jandeboercatamarans.nl

### Italy

Vanni Gori  
Multi SRL  
Via Mazetta 2, Firenze,  
50125, Italy  
info@multiscafi.com

### Spain

Sten Sorensen  
Calle Castella 12 - Urb Coveta Fuma,  
03560 El Campello, Spain  
ss@power-board.info

### Sweden

Ulrich Lindberg  
Corsair Marin AB  
Odengatan 31 c,  
SE 11351 Stockholm, Sweden  
ulrich@trimaran.se

### UK

Mark Jarvis  
Ryan Vick  
Multihull World Brokerage Network  
Thornham Marina, Emsworth, Hants,  
PO10 8DD, UK  
multihullworld@hotmail.co.uk

### Russia

Eugene Burusov  
Chernomor company  
burus@linorusso.ru

## ASIA

### Australia

New South Wales, Victoria, Tasmania,  
South Australia

David Renouf  
Linda Renouf  
Just Multihulls  
15 Edgecliff Blvd, Collaroy, NSW,  
2097 Australia  
dprenouf@aol.com  
ljrenouf@aol.com

### Queensland

Andrew Crawford  
Multihull Central  
andrew@seawindcats.com

### China

Northeast China incl. Shanghai

Markus Winter  
John Coffin  
Elite Yachting China  
No. 227 Jinshang Road, Jinze Town,  
Qingpu District, 201718, Shanghai,  
China  
markus@elite-yachting-china.com john@  
elite-yachting-china.com

### New Caledonia, Tahiti, Guadeloupe

Gilles  
La Landriais Nautique  
4 Impasse Des Fous De Bassan,  
17420 Saint-palais sur mer, France  
lalandriaisnautique@wanadoo.fr

### Singapore, Malaysia, Indonesia

Scott McCook  
Alice Lim  
Pro Sail Asia Pte Ltd  
9 Raffles Place  
Level 17 Republic Plaza II  
Singapore 048619  
T: 65-6543-2439  
M: 65-9663-1425 (Alice Lim)  
scott.mccook@prosailasia.com  
alichelim@prosailasia.com

### Thailand

Robert Garner  
Sail In Siam Co., Ltd.  
107/37 Moo 1, Jomtien Yacht Club 3  
Tambon Na Jomtien, Sattahip, Chonburi,  
Amphur, 20250, Thailand  
bgarner@loxinfo.co.th

### Vietnam

Ruurd van Putten  
Sailing Center Vietnam  
7 Hien Luong, Phuoc Hoa,  
Nha Trang City, Vietnam  
ruurd@sailing.vn

---

## SOUTH AMERICA

### Chile

Patricia Letellier  
Pro-Nautica Ltd.  
AV. 8506 Las Condes  
Santiago, Chile  
pletelier@pro-nautica.cl

### Columbia

Hugo Berrio Jimenez  
Oficina Cra 100 # 5-169 309-B, Cali,  
Colombia, South America  
hugoberrio7@gmail.com

### Rest of World

Corsair Marine International  
7 Go O Moi Street, Phu Thuan Ward,  
District 7, HCMC, Vietnam  
info@corsairmarine.com  
T: 84-(8)-3873-3620  
www.corsairmarine.com



[www.corsairmarine.com](http://www.corsairmarine.com)

CORSAIR MARINE SAILING MANUAL

7 Go O Moi ▪ PHU THUAN Ward ▪ District 7 ▪ Ho Chi Minh City ▪ Vietnam

